



A Practical Guide to AutoCAD® 2020

Tracy Chadwick and Rick Ellis

Foreword written by Lynn Allen



A CADapult Press Publication

Copyright

Copyright © CADapult Press, Inc. 2019

All rights reserved. No part of this publication may be reproduced in any form, or by any means electronic, mechanical, recording, photocopying, or otherwise, without written permission from the publisher, except for brief quotations used in reviews, or for marketing purposes specific to the promotion of this work.

ISBN: 978-1-934865-43-9

Although CADapult Press has made every attempt to ensure the accuracy of the contents of this book, the publisher and author make no representations or warranty with respect to accuracy or completeness of the contents in this book, including without limitation warranties of fitness for a particular purpose. The datasets included in this book are for training purposes only.

Autodesk screen shots reprinted with the permission of Autodesk, Inc.

Autodesk, AutoCAD, DWG, and the DWG logo are registered trademarks or trademarks of Autodesk, Inc., and/or its subsidiaries and/or affiliates in the USA and other countries. All other trademarks are the property of their respective owners.

Published in the United States of America by:

CADapult Press

(503) 829-8929

books@cadapult-software.com

Printed and manufactured in the United States of America

About the Authors

Tracy Chadwick serves as coordinator and instructor for the Computer Drafting Technology program at Hutchinson Community College in Hutchinson, Kansas. He is responsible for teaching a wide range of courses, including those on engineering graphics, AutoCAD software, Inventor software, and Revit Architecture software.

Tracy has been an AutoCAD user since 1995, and has been teaching AutoCAD classes to working professionals and college students since 2001. His experience and dedication to teaching led to him being recognized by Autodesk, Inc. with the North America Award for Distinguished Performance in AutoCAD Software Training.

Tracy has also been recognized as a top rated speaker at Autodesk University, where he has presented for several years. He has recently begun serving as a mentor to first-time Autodesk University speakers.

Tracy can be reached at: tracy@cadapult-software.com

Rick Ellis has worked with and taught AutoCAD Map 3D since the mid-90s, along with Civil 3D and other Autodesk products. He is the Author of several critically acclaimed books on AutoCAD Map 3D, Civil 3D and Land Desktop.

Rick continues to use AutoCAD Map 3D on projects in a production environment, in addition to teaching classes to organizations both large and small.

This practical background and approach has made him an award winning speaker at Autodesk University and a sought after instructor by organizations around the world.

Rick can be reached at: rick@cadapult-software.com

Acknowledgements

Thank you to my wonderful wife Candace, and my two amazing daughters Sydney and Casey. Without their support I could never have completed this book. Thank you to all the students of the Computer Drafting Technology program at Hutchinson Community College. I am honored to have played a part in helping so many students achieve fulfilling careers over the last two decades. Thank you to Vince Puyear, who first introduced me to AutoCAD back in 1995. He started as my instructor, then later became my colleague, mentor, and friend. Thank you to Amber Brawner for lending her graphic design talent to this book, and for being a great friend. Last, but not least, thank you to Rick Ellis and CADapult Press for helping me to achieve my dream of being an author, so that I may spread my love for AutoCAD from beyond central Kansas to the world!

-Tracy Chadwick

A Practical Guide to AutoCAD® 2020

Introduction

Congratulations on choosing this course to help you learn how to use AutoCAD 2020. The term “practical” is used in the title because this course focuses on what you need to effectively use AutoCAD 2020, and does not complicate your learning experience with unnecessary details of every feature in the product. Should you want to pursue aspects of features and functionality in greater detail than provided in this course, you are directed and guided to that information.

Each lesson contains the concepts and principles of each feature to provide you with the background and foundation of knowledge that you need to complete the lesson. You then work through exercises to reinforce your understanding and provide you with practice on common tasks that other professionals are performing with AutoCAD 2020 in the workplace every day.

When you complete this course, you will be armed with the background and knowledge to apply AutoCAD to your job tasks, and become more effective and productive in your job.

Course Objectives

The objectives of this course are performance based. In other words, once you have completed the course, you will be able to perform each objective listed. If you are already familiar with AutoCAD, you will be able to analyze your existing workflows, and make changes to improve your performance based on the tools and features that you learn and practice in this course.

After completing this course, you will be able to:

- Understand the user interface
- Navigate through drawings with pan and zoom commands
- Create drawing objects, including lines, arcs, and circles
- Create and modify polylines, including rectangles and polygons
- Use Layers to differentiate drawing objects
- Draw using Polar Tracking and coordinate methods
- Use Object Snaps and Object Snap Tracking
- Modify drawing objects
- Duplicate drawing objects
- Extract information from drawings with measuring tools
- Create and modify hatch patterns
- Create, insert, and modify blocks
- Work with external references
- Import a PDF
- Create and scale paper space layouts and viewports
- Print scale drawings and check plots
- Detail drawings with text, dimensions, and leaders

Downloading and Installing the Datasets

In order to perform the exercises in this book, you must download a zip file and install the datasets.

Type the address below into your web browser to load the page where you can download the dataset.

www.cadapult-software.com/data

Unzip the Files

Unzip the file **APG_AutoCAD2020.zip** directly to the C drive. The zip file will create the following folder structure:

C:\A Practical Guide\AutoCAD 2020\Files for Exercises

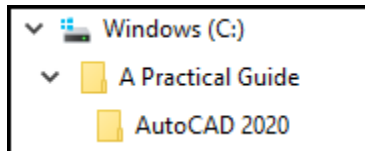

Exercises

The exercises in this course have been carefully chosen and designed to represent common tasks that are performed by design professionals.

The exercise files are from many different industries, and are meant only to be examples. It's important to focus on the tools being shown and how you could apply them to your project and industry.

Exercises provide higher level process information throughout the exercise tasks. You are given information about not only what to do, but why you are doing it. In most cases, an image is included to help guide you.

Table of Contents

Chapter 1 Introduction to AutoCAD	1
1.1. Lesson: Navigating the AutoCAD User Interface	2
1.1.1 Navigating the AutoCAD Interface	8
1.2. Lesson: Working with AutoCAD Drawing Files	10
1.2.1 Working with AutoCAD Drawings	17
1.3. Lesson: Basic AutoCAD Tools	20
1.4. Lesson: Selection Techniques.....	26
1.4.1 Selection Techniques.....	29
Chapter 2 Drawing Lines and Working with Layers	31
2.1. Lesson: Drawing Lines	32
2.1.1 Drawing Lines	35
2.2. Lesson: Drawing with Cartesian Coordinates	37
2.2.1 Drawing a Rectangle with Absolute Coordinates.....	41
2.2.2 Drawing a More Complex Shape with Absolute Coordinates.....	42
2.2.3 Drawing a Rectangle with Relative Coordinates.....	43
2.2.4 Drawing a More Complex Shape with Relative Coordinates	44
2.2.5 Drawing a Rectangle with Polar Coordinates	46
2.2.6 Drawing a More Complex Shape with Polar Coordinates.....	47
2.3. Drawing with Polar Tracking.....	49
2.3.1 Drawing a Rectangle with Polar Tracking.....	56
2.3.2 Drawing a More Complex Shape with Polar Tracking	58
2.3.3 Drawing with Additional Polar Tracking Angles	60
2.3.4 Drawing with Architectural Units	62
2.4. Drawing with Layers	65
2.4.1 Drawing with Layers.....	72
2.4.2 Changing the Layers of Existing Objects.....	74
2.4.3 Modifying Layer States	75
2.4.4 Creating and Modifying Layers	77
Chapter 3 Drawing Additional Objects (Part I)	81
3.1. Drawing Circles.....	82
3.1.1 Drawing Circles with the Center, Radius and Center, Diameter Methods.....	85
3.1.2 Additional Practice with the Center, Radius and Center, Diameter Methods	86
3.1.3 Drawing Circles with the 2-Point and 3-Point Methods.....	87
3.1.4 Drawing Circles with Tangent Methods	88

3.2. Drawing Rectangles	90
3.2.1 Drawing Rectangles	92
3.2.2 Additional Practice Drawing Rectangles	94
3.3. Drawing Polygons	95
3.3.1 Drawing Polygons.....	98
3.3.2 Additional Practice Drawing Polygons.....	99
Chapter 4 Object Snaps and Object Snap Tracking.....	101
4.1. Drawing with Object Snaps.....	102
4.1.1 Drawing with Endpoint, Midpoint, and Quadrant Object Snaps	109
4.1.2 Drawing with Center and Tangent Object Snaps	112
4.1.3 Drawing with Node and Perpendicular Object Snaps	114
4.1.4 Drawing with Intersection and Geometric Center Object Snaps	116
4.1.5 Drawing with Object Snap Overrides	118
4.1.6 Additional Practice Drawing with Object Snap Overrides	120
4.2. Drawing with Object Snap Tracking.....	122
4.2.1 Tracking Off of a Single Point with Object Snap Tracking	127
4.2.2 Object Snap Tracking of Multiple Points	129
Chapter 5 Drawing Additional Objects (Part II).....	131
5.1. Drawing Arcs.....	132
5.1.1 Drawing Arcs	138
5.1.2 Additional Practice Drawing Arcs	140
5.2. Drawing and Editing Polylines	143
5.2.1 Drawing Polylines	150
5.2.2 Drawing Polylines with Varying Widths	152
5.2.3 Editing Polylines	155
Chapter 6 Modifying Drawing Objects.....	159
6.1. Moving Drawing Objects	160
6.1.1 Moving Drawing Objects.....	162
6.1.2 Additional Practice Moving Objects.....	163
6.2. Scaling Drawing Objects	168
6.2.1 Scaling Objects.....	171
6.2.2 Scaling Drawing Objects with the Reference Option	174
6.3. Stretching Drawing Objects	176
6.3.1 Stretching Drawing Objects	178

6.4. Rotating Drawing Objects.....	181
6.4.1 Rotating Drawing Objects	185
6.4.2 Rotating Objects with Polar Tracking.....	188
6.4.3 Rotating Objects with the Reference Option.....	190
6.5. Trimming Drawing Objects	192
6.5.1 Trimming Drawing Objects.....	196
6.6. Extending Drawing Objects	199
6.6.1 Exercise: Extending Drawing Objects.....	203
6.6.2 Exercise: Additional Practice Trimming and Extending Objects.....	204
6.7. Creating Rounded Corners with the Fillet Command.....	209
6.7.1 Filleting Drawing Objects	214
6.7.2 Additional Practice Filleting Drawing Objects	218
6.8. Creating Angled Corners with the Chamfer Command.....	220
6.8.1 Chamfering Drawing Objects	228
Chapter 7 Duplicating Drawing Objects.....	235
7.1. Copying Drawing Objects	236
7.1.1 Copying Drawing Objects	238
7.1.2 Exercise: Additional Practice Copying Objects.....	240
7.2. Mirroring Drawing Objects	242
7.2.1 Mirroring Drawing Objects	245
7.2.2 Additional Practice Mirroring Objects.....	247
7.3. Creating Rectangular Arrays of Drawing Objects.....	250
7.3.1 Creating a Rectangular Array	254
7.3.2 Additional Practice Creating Rectangular Arrays.....	258
7.4. Creating Polar Arrays of Drawing Objects.....	261
7.4.1 Creating a Polar Array.....	267
7.4.2 Additional Practice Creating Polar Arrays.....	271
7.4.3 Creating Polar Arrays with Multiple Rows.....	273
7.5. Creating Path Arrays of Drawing Objects.....	275
7.5.1 Creating Path Arrays Using the Measure Method	280
7.5.2 Creating Path Arrays Using the Divide Method	283
7.6. Offsetting Drawing Objects.....	285
7.6.1 Offsetting Drawing Objects	289
7.6.2 Additional Practice Offsetting Objects.....	292
7.7. Modifying Drawing Objects with Grips.....	295
7.7.1 Grip Editing Drawing Objects.....	300

Chapter 8 Inquiry Tools	305
8.1. Measure commands.....	306
8.1.1 Measuring Distance, Area, and Perimeter	322
8.1.2 Measuring Distance, Radius, Area, and Angle	325
8.1.3 Measuring Angles.....	329
8.1.4 Measuring with the Quick Measure Tool.....	331
8.2. Object Properties	333
8.2.1 Viewing and Modifying Object Properties.....	340
Chapter 9 Adding and Modifying Hatch Patterns	345
9.1. Adding and Modifying Hatch Patterns.....	346
9.1.1 Adding Hatch Patterns.....	353
9.1.2 Additional Practice Adding Hatch Patterns.....	357
Chapter 10 Working with Blocks, External References, and PDF Files	363
10.1. Inserting Blocks.....	364
10.1.1 Inserting Blocks with the Blocks Palette.....	373
10.1.2 Inserting Dynamic Blocks	380
10.1.3 Inserting Blocks with Tool Palettes.....	383
10.1.4 Inserting Blocks with DesignCenter.....	386
10.2. Creating Blocks	390
10.2.1 Creating Local Blocks.....	397
10.2.2 Creating Global Blocks.....	403
10.3. Attaching External References.....	408
10.3.1 Working with External References	413
10.4. Importing PDF Files	418
10.4.1 Importing PDF Files.....	422
Chapter 11 Plotting Drawings	427
11.1. Plotting Drawings from Model Space.....	428
11.1.1 Plotting from Model Space	431
11.2. Plotting Drawings from Paper Space	436
11.2.1 Plotting from Paper Space.....	442
Chapter 12 Annotating Drawings	449
12.1. Adding and Modifying Text.....	450
12.1.1 Adding Text Notes to a Drawing.....	455
12.1.2 Additional Practice Adding Text Notes to a Drawing.....	458

12.2. Adding and Modifying Dimensions	461
12.2.1 Adding Linear Dimensions	471
12.2.2 Adding Aligned and Angular Dimensions	473
12.2.3 Adding Radius and Diameter Dimensions	475
12.2.4 Adding Continuous and Baseline Dimensions	479
12.3. Adding and Modifying Leaders	482
12.3.1 Adding Leaders	490
12.3.2 Adding Balloons with the Multileader Command	493
Index	499

Foreword

Welcome to the wonderful world of AutoCAD. I say that somewhat tongue and cheek as learning AutoCAD can be somewhat daunting – and no doubt why you’ve chosen to pick up this book. I commend you for not trying to learn AutoCAD completely on your own (a dreadful route to take) but for relying on the skillful guidance of Tracy Chadwick and Rick Ellis. These two award winning authors have been teaching AutoCAD for many years and know exactly what it takes to lead the beginning user through the oft overwhelming tools inside of AutoCAD. This ***A Practical Guide of AutoCAD 2020*** will focus on the all-important basics of the product and steer you clear of the nonessential tools (you can tackle those later when you are more seasoned!) There is a right and a wrong way to use AutoCAD...this book will ensure that you learn how to use it the “right” way!

I taught AutoCAD at the collegiate and professional level for 11 years before joining Autodesk in their training department. I know the importance of good training materials and I know a great AutoCAD book when I see it. You are looking at one right now. Tracy and Rick have mastered the art of writing in terms that we can all understand without a need to impress or complicate the task at hand. Their goal is simple: to help you successfully use AutoCAD for your design work. They have taken their many years of training expertise and rolled it all into this well massaged book. How I wish I’d had this book when I was training people how to use AutoCAD!

In my 20+ year role as Autodesk Evangelist, I had the distinct privilege of working with Tracy and Rick at Autodesk University and other conferences. Their presentations are always highly rated and very popular with attendees. They have that special knack of connecting with an audience and making the difficult sound easy – which is exactly what you need when you are learning to use AutoCAD. You will experience this as you make your way through the chapters of this book.

A Practical Guide of AutoCAD 2020 also includes real-world examples from many different industries. You won’t be drawing any Mickey Mouses or smiley faces, but actual drafting examples. Let’s face it – you wouldn’t get a job with that limited skillset (well...unless you go work for Disney). The variety of practical examples used with practical commands is the perfect combination to get you prepared for drafting and designing in the real world.

Use this book to build a firm foundation for designing with AutoCAD. Those users with a firm foundation of the product do best overall in successfully mastering the product (another reason to read this book). Physically do as many exercises in the book as possible and you’ll be on the road to becoming a great AutoCAD user!

I’m pretty sure that your first thought when you’re finished with this book is going to be...“When are Tracy and Rick going to come out with an ***Advanced Practical Guide of AutoCAD?***” I know that’s my question!

Lynn Allen

Global Technology Evangelist

In her 20+ year career as Autodesk Technology Evangelist, Lynn Allen has spoken to more than a half million design professionals in over 50 countries throughout the world. Her online reach over the years easily reaches into the millions. An early CAD entrepreneur, Lynn taught AutoCAD at the corporate and collegiate level for 11 years before joining Autodesk. A popular columnist for Cadalyst magazine for over two decades, she is the face behind hundreds of software videos including the series “AutoCAD Tips and Tricks with Lynn Allen”. A sought-after public speaker with a unique comedic style, Lynn was the host of Autodesk University for over a decade and is always one of the highest rated presenters at the many worldwide Autodesk Universities. She is also the author of three technical books focused on AutoCAD software.

Sample Lesson

6.4. Rotating Drawing Objects

Introduction

In this lesson, you learn how to rotate drawing objects.

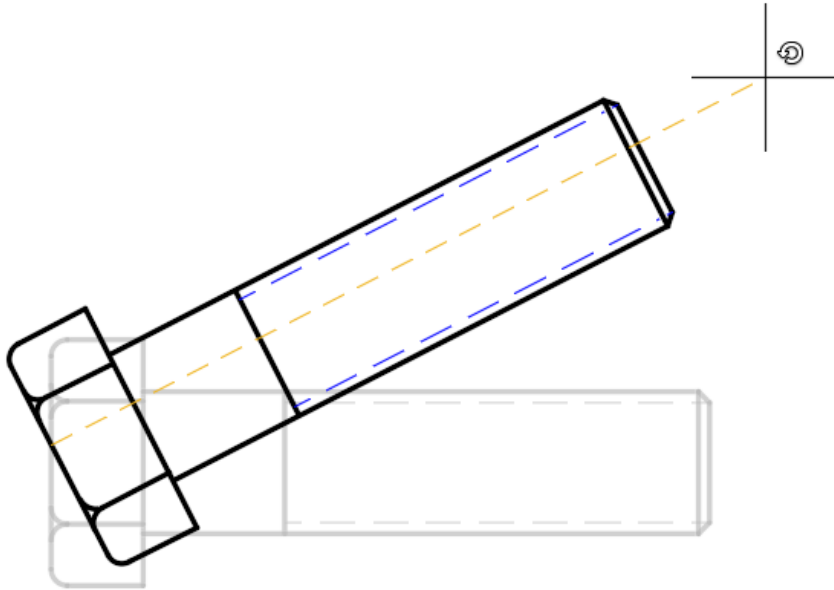

Key Concepts

Concepts and key terms covered in this lesson are:

- Rotating Objects
- Base Point
- Rotation Angle
- Reference Angle

Objectives

After completing this lesson, you will be able to:

- Rotate drawing objects.

About the Rotate Command

Many times while drawing you will have the need to adjust the orientation of drawing objects by rotating them. The Rotate command can achieve this in a few simple steps.

Starting the Rotate Command

The **Rotate** command is located at **Ribbon: Home** ⇒ **Modify** ⇒ **Rotate**.

Alternatively, you can type **RO** then press **[Enter]** at the keyboard.

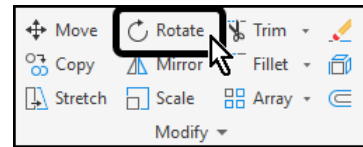

After starting the Rotate command, you are prompted to select the objects to be rotated.

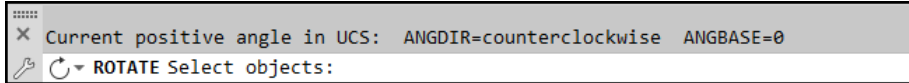

The Rotate command will allow you to select as many objects as you want. When you are finished selecting objects you must press **[Enter]** at the keyboard to move on to the next step.



Next you will specify the base point. This point will remain in the same location while the rest of the selected objects rotate around it.



Finally, the Command line asks for the rotation angle. The angle can be specified by typing a value or by selecting a point on-screen.

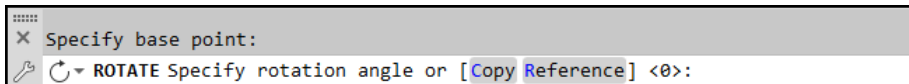

When entering a rotation angle value, it is important to remember that by default in AutoCAD, angles are positive when rotating in the counterclockwise direction; angles are negative when rotating in the clockwise direction.

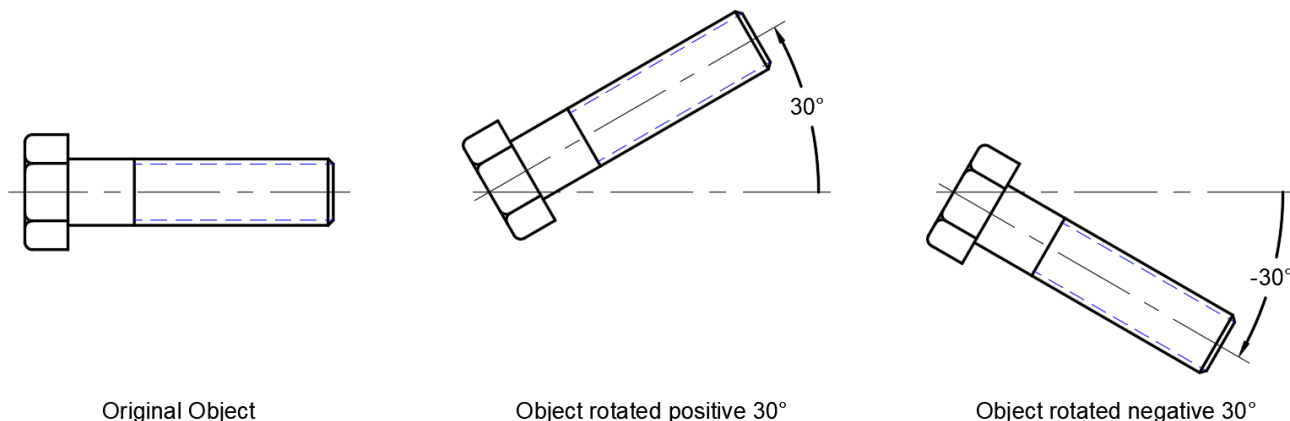

Instead of typing the rotation angle value, you can also pick a point on-screen. Turn on *Polar Tracking* to ensure that the rotation angle is precise. In the example below the Incremental Angle value of *Polar Tracking* has been set to 30 degrees. This could be a more efficient workflow because you do not need to be concerned with whether or not an angle is positive or negative. Instead, you simply click when the object is located on the appropriate tracking angle.

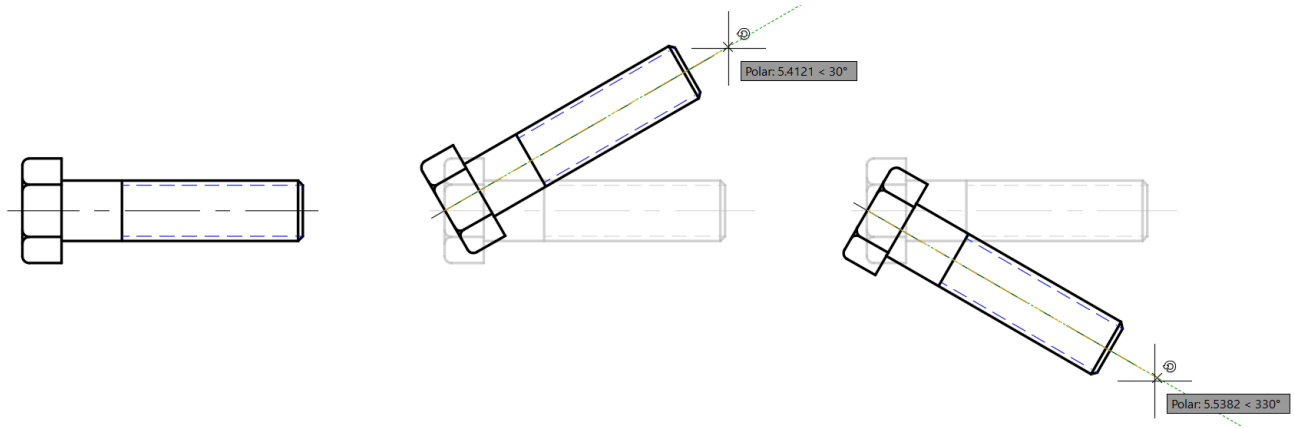

Specifying the Reference Angle

Occasionally when working in a drawing, you may find the need to rotate an object to return it to a standard orientation. For example, the bolt in the image to the right is currently at an angle, and it needs to be rotated until it is back to horizontal.

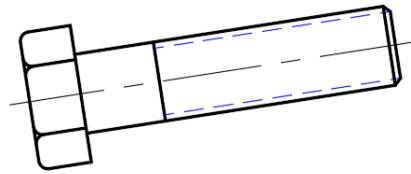

This is a fairly simple process if the object was rotated at a known angle, such as 30 degrees; you could simply rotate the object negative 30 degrees to return it to horizontal. However, if the object has been rotated at an unknown angle, the process could be more difficult. One possibility is to measure the angle from horizontal, then rotate using a negative value.

In the image to the right, the angle of the bolt has been measured and found to be nine degrees.

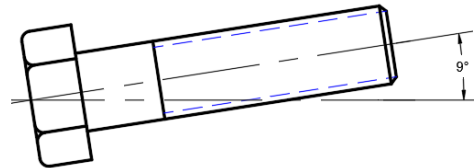

The first instinct might be to rotate the object negative nine degrees to return it to horizontal. This might not work precisely, because the nine degree dimension could be rounded off. A closer look reveals that the angle is slightly less.

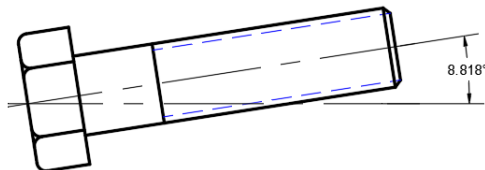

Using this new, more precise value could still lead to an incorrect drawing because this value is most likely rounded off as well.

The much more precise and quicker solution is to use the Reference option of the Rotate command.

In this example the centerline of the bolt will serve as the reference angle. Therefore, the left endpoint of the centerline will serve as the basepoint.

1. Begin the Rotate command and select the objects to be rotated.
2. Specify the basepoint.
3. Choose the **[Reference]** option in the Command line.

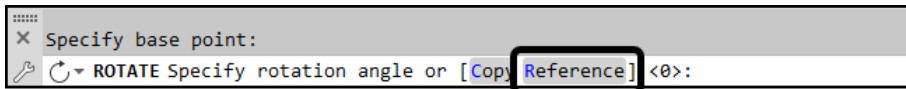
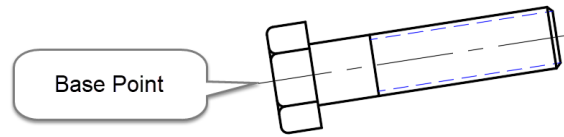

4. Select the two endpoints of the centerline to represent the new reference angle.

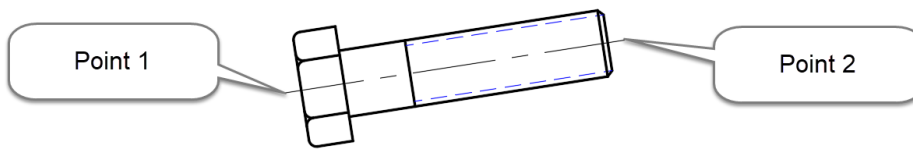

5. Move the crosshairs horizontally to the right of the basepoint along the **0** degree *Polar Tracking* angle.
6. Select a point to rotate the bolt into place.

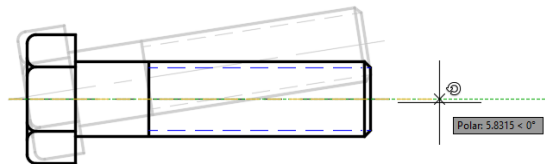

Exercises: Rotating Drawing Objects

In these exercises, you will rotate several drawing objects.

You do the following:

- Start the Rotate command.
- Select objects.
- Specify base points.
- Specify a rotation angle by typing a value.
- Specify a rotation angle with *Polar Tracking*.
- Use the reference option to orient drawing objects.

6.4.1 Rotating Drawing Objects

In this exercise you will use the Rotate command to adjust the orientation of several doors.

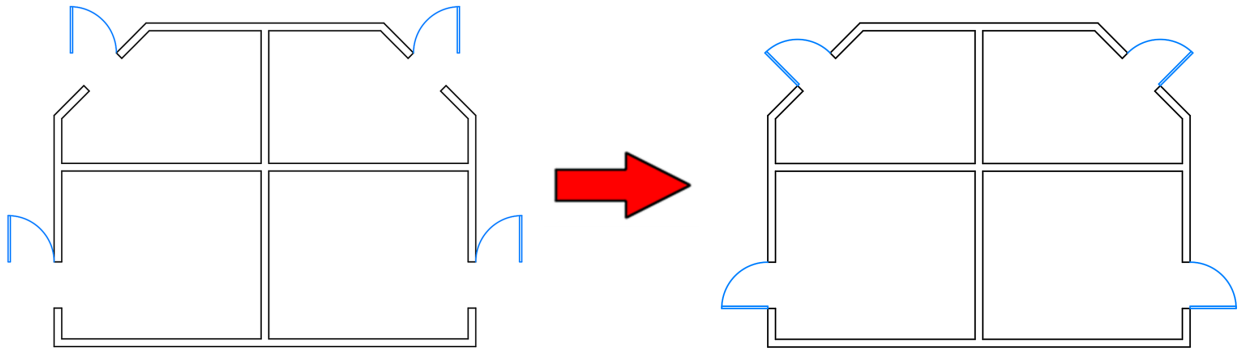

1. **Open** drawing **6.4.1 Rotating Objects 1.dwg**.
2. Set **Endpoint** as a *Running Object Snap*.

Four doors have been placed, but they need to be rotated into place. Start with the door in the lower left, then work clockwise around the building.

3. Zoom to the lower-left quadrant of the building.
4. Select **Ribbon: Home** ⇒ **Modify** ⇒ **Rotate**.

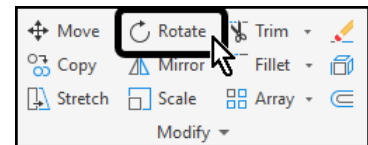

5. Select the door.
6. Press **[Enter]** at the keyboard to finish selecting objects.

You are now prompted to select the base point.

7. Select the point where the arc touches the wall to specify it as the base point.

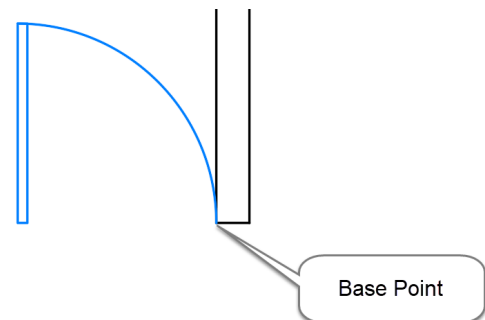

You are now prompted to specify the rotation angle.

8. At the Command line type **90** then press **[Enter]** at the keyboard.

The door is rotated into place.

9. Zoom to the upper-left quadrant of the building.

10. Select **Ribbon: Home** ⇒ **Modify** ⇒ **Rotate**.

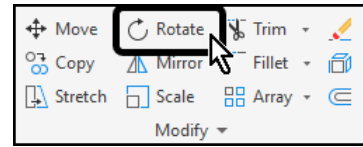

11. Select the door.

12. Press **[Enter]** at the keyboard to finish selecting objects.

You are now prompted to select the base point.

13. Select the point where the arc touches the wall to specify it as the base point.

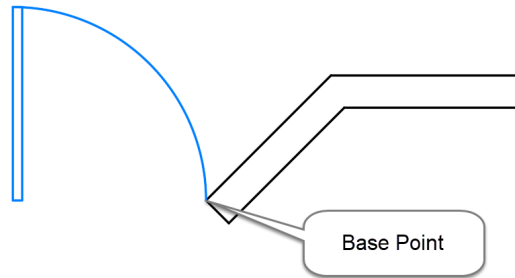

You are now prompted to specify the rotation angle.

14. At the Command line type **45** then press **[Enter]** at the keyboard.

The last two doors will be rotated in the clockwise direction, which will require negative rotation angles.

15. Zoom to the upper-right quadrant of the building.

16. Select **Ribbon: Home** ⇒ **Modify** ⇒ **Rotate**.

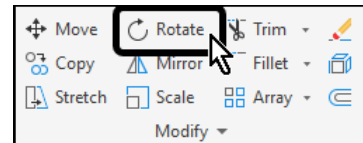

17. Select the door.

18. Press **[Enter]** at the keyboard to finish selecting objects.

You are now prompted to select the base point.

19. Select the point where the arc touches the wall to specify it as the base point.

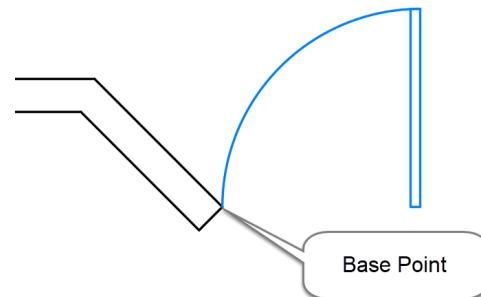

You are now prompted to specify the rotation angle.

20. At the Command line type **-45** then press **[Enter]** at the keyboard.

Next you will rotate the final door.

21. Zoom to the lower-right quadrant of the building.

22. Select **Ribbon: Home** ⇒ **Modify** ⇒ **Rotate**.

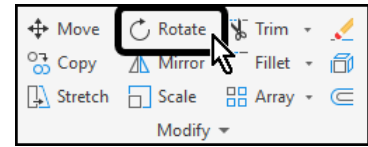

23. Select the door.

24. Press **[Enter]** at the keyboard to finish selecting objects.

You are now prompted to select the base point.

25. Select the point where the arc touches the wall to specify it as the base point.

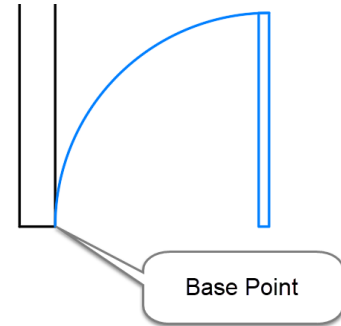

You are now prompted to specify the rotation angle.

At the Command line type **-90** then press **[Enter]** at the keyboard.

The completed drawing appears as shown.

26. **Save** the drawing.

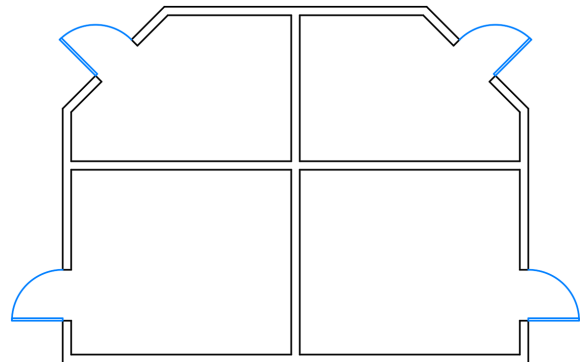

6.4.2 Rotating Objects with Polar Tracking

In this exercise you will use the Rotate command and *Polar Tracking* to speed up the rotate process.

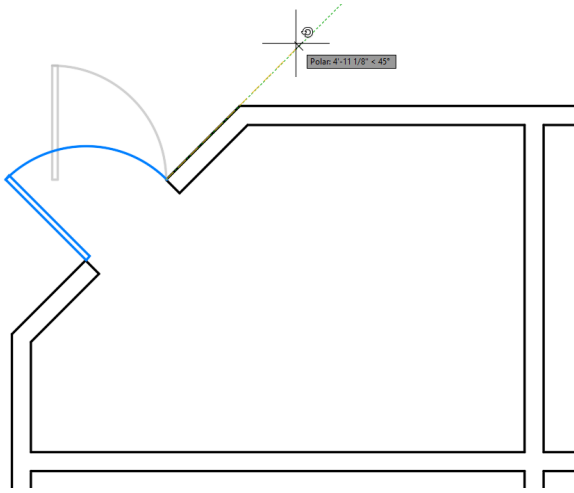

1. **Open** drawing **6.4.2 Rotating Objects 2.dwg**.
2. Set **Endpoint** as a *Running Object Snap*.
3. Select the fly-out arrow next to the *Polar Tracking* button and select **45** degree increment angles.
4. If necessary, select the *Polar Tracking* button to turn it on.

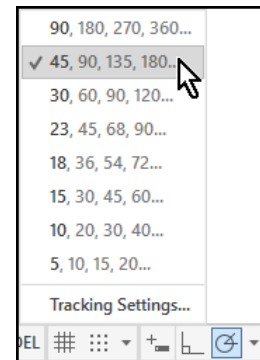

5. Zoom to the lower-left quadrant of the building.
6. Select **Ribbon: Home** ⇒ **Modify** ⇒ **Rotate**.

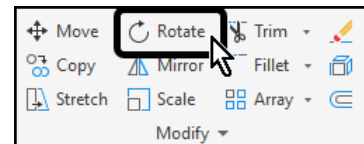

7. Select the door.
8. Press **[Enter]** at the keyboard to finish selecting objects.

You are now prompted to select the base point.

9. Select the point where the arc touches the wall to specify it as the base point.

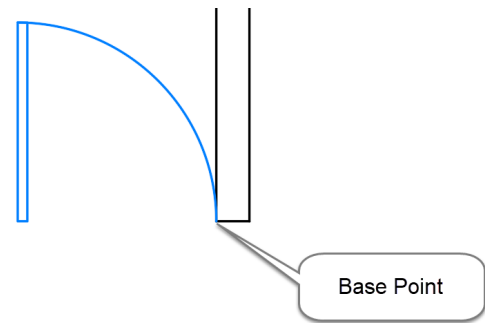

You are now prompted to specify the rotation angle.

10. Move the crosshairs above the previous point, until it snaps on to the **90** degree *Polar Tracking* angle, then select a point.

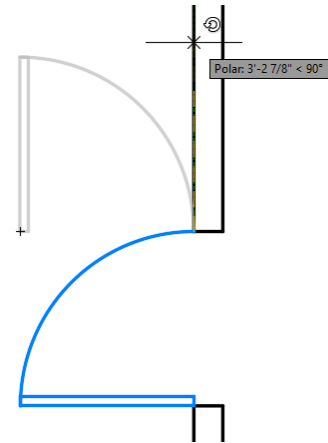

The door is rotated into place.

11. Zoom to the upper-left quadrant of the building.
12. Select **Ribbon: Home** ⇒ **Modify** ⇒ **Rotate**.

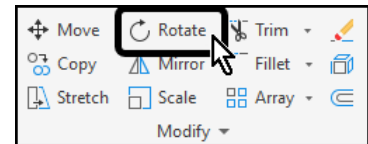

13. Select the door.
14. Press **[Enter]** at the keyboard to finish selecting objects.

You are now prompted to select the base point.

15. Select the point where the arc touches the wall to specify it as the base point.

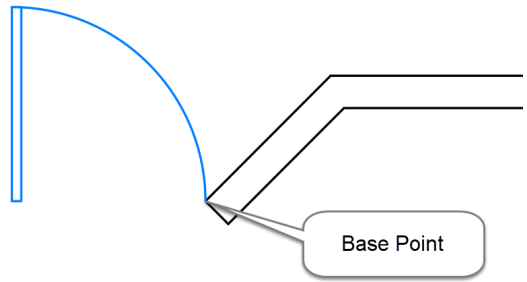

You are now prompted to specify the rotation angle.

16. Move the crosshairs above and to the right of the previous point, until it snaps on to the **45 degree Polar Tracking** angle, then select a point.

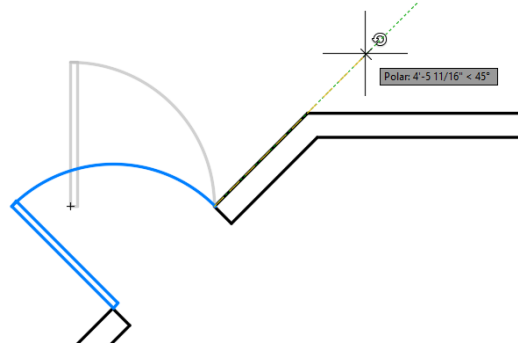

17. Repeat the process to complete the right side of the drawing.
18. **Save** the drawing.

6.4.3 Rotating Objects with the Reference Option

In this exercise you will use the Reference option of the Rotate command to adjust the orientation of an object.

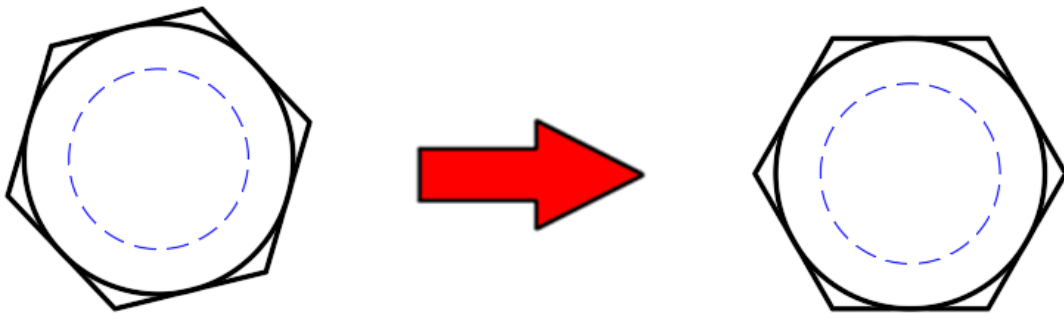

1. **Open** drawing **6.4.3 Rotating Objects 3.dwg**.
2. Set **Endpoint** as a Running Object Snap.

A bolt head has been rotated at an unknown angle. You will rotate it until the top and bottom edges are horizontal.

3. Select **Ribbon: Home** ⇒ **Modify** ⇒ **Rotate**.

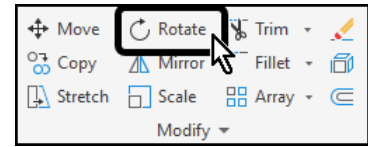

4. Select the objects that make up the bolt head.
5. Press **[Enter]** at the keyboard to finish selecting objects.

You are now prompted to select the base point.

6. Select the lower-left corner to specify it as the base point.

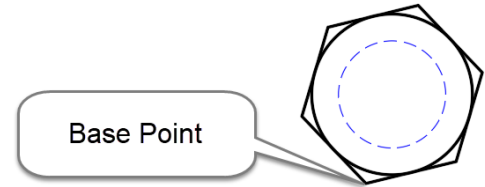

You are prompted for a rotation angle. By default, AutoCAD uses 0 as the reference angle, meaning that you are rotating from horizontal. In this case the reference angle should match the bottom edge of the bolt head. Since that value is unknown, you will select the two endpoints of that line to specify it as the new reference angle.

7. At the Command line select the **[Reference]** option.

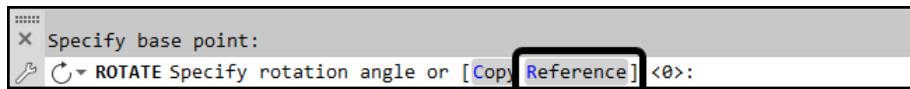

You are prompted to specify the reference angle.

8. Click the lower-left point.
9. Click the lower-right point.

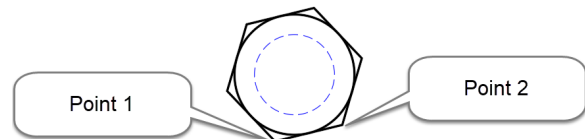

The reference angle now matches the bottom edge of the bolt head.

10. Move the crosshairs horizontally to the right along the **0** degree *Polar Tracking* angle.
11. Select a point to rotate the bolt head into place.

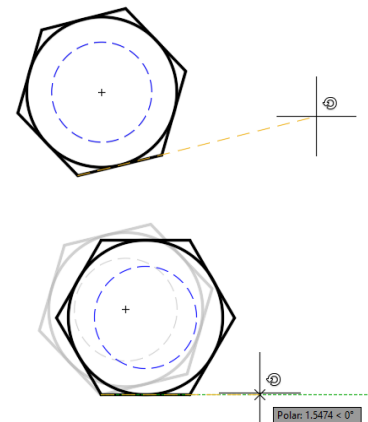

The top and bottom edges of the bolt head are now horizontal.

12. **Save** the drawing.

Lesson Review

In this lesson, you learned how to rotate drawing objects both by typing angle values at the Command line and with the aid of *Polar Tracking*.

Index

[F2]	22	External References	408
Absolute Coordinates	38	External References Palette	409
Additional Tracking Angles	52	File Tabs	6
Aligned Dimension	464	File Types	11
Angles	40	Fillet command	210
Angular Dimension	465	Freezing and Thawing Layers	67
Application Menu	5	Geometric Center Snap	106
Arc	133	Grip Editing	296
Area	316	Hatch patterns	347
Associative Dimensions	468	Help	6
automatic save	15	Increment Tracking Angles	50
automatic save files	15	Inscribed	96
backup copy	15	Insert command	409, 419
Baseline Dimension	467	Insert Snap	108
Block Editor	394	Inserting Blocks	365
Blocks	365, 409	Intersection Snap	106
Boundary edges	200	Joining Lines and Arcs	148
Cartesian Coordinates	38	Keyboard Options	21
Center Snap	106	Lasso	28
Chamfer command	221	Layer Properties Manager	69
Changing the Layer of Existing Objects	66	Layer States	67
Circle	83	Layers	66
Circumscribed	97	Layout Tabs	7
Closing a File	16	Layouts	439
Closing a Polyline	147	Leaders	483
Command Line	7	Line	33
Command Line Options	22	Linear Dimension	464
Continue Dimension	466	Linetype	70
Copy command	237	Lineweight	71
Create Block command	391	List command	335
Crosshairs	6	Locking Layers	68
Crossing selection method	27	Match Properties	334, 350
Current Layer	66	Measure Angle	313, 314
Cutting edges	193	Measure Area	316
DesignCenter	372	Measure Commands	307
Diameter Dimension	466	Measure Distance	309
Dimensioning	462	Measure Radius	311
Direct Distance Entry	50	Midpoint Snap	105
Drafting Settings Dialog Box	104	Mirror command	243
Drawing Units	308	Model Space	429, 440
Drawing Window	6	Move command	161
Dynamic Blocks	370	Multileader	483
Edit Polyline	146	Multiline Text	451
Endpoint Snap	105	Multiple Drawings	16
Erasing Objects	25	Navigation Bar	24
Explode	149, 264, 368	Nearest Snap	108
Extend command	200	New	11
Extension Snap	125	Node Snap	108
External Reference Fading	411	Object Snap Tracking	123
External Reference Path Type	411	Object Snaps	103, 125
External Reference Type	410	Offset command	286
External Reference Updating	411	Open	13

ORTHO	50	Reference Angle	183
OSNAP	103	Reference Option	169
OTRACK	123	Relative Coordinates	39
Page Setup Manager	437	Removing objects from a selection set	28
Pan	24	Ribbons	5
Paper Space	437	Right-Click Context Menus	23
Parallel Snap	126	Rotate command	182
Path Array	276	Running Object Snaps	103
PDF data to import	420	Save	14
PDF Import	419	Save As	14
Perpendicular Snap	107	Scale command	169
Plot style table	430	Selection Techniques	26
Plotting	429, 437	Status Bar	7
Polar Array	262	Stretch command	177
Polar Coordinates	40	Tangent Snap	107
Polar Tracking	50	Text	451
Polygon	96	Text Window	22
polyline	91	Tool Palettes	371
Polyline Width	145, 147	Tracking Angles	125
Polylines	144	Trim command	193
Properties palette	337	Turning Layers On and Off	67
Properties Panel	334	UCS Icon	7
QNew	11	Undo	25, 34
Quadrant Snap	107	Units	53, 308
Quick Access Toolbar	6	View Cube	6, 24
Quick Measure	320	Viewport Scale	441
Quick Select	339	Viewports	439
Radius Dimension	465	Window selection method	27
Rectangle	91	Write Block command	393
Rectangular Array	251	Zoom	24
Redo	25		



A Practical Guide to Autodesk Civil 3D® 2020

Rick Ellis



A CADapult Press Publication

Copyright

Copyright © CADapult Press, Inc. 2019

All rights reserved. No part of this publication may be reproduced in any form, or by any means electronic, mechanical, recording, photocopying, or otherwise, without written permission from the publisher, except for brief quotations used in reviews, or for marketing purposes specific to the promotion of this work.

ISBN: 978-1-934865-44-6

Although CADapult Press has made every attempt to ensure the accuracy of the contents of this book, the publisher and author make no representations or warranty with respect to accuracy or completeness of the contents in this book, including without limitation warranties of fitness for a particular purpose. The datasets included in this book are for training purposes only.

Autodesk screen shots reprinted with the permission of Autodesk, Inc.

Autodesk, AutoCAD, DWG, the DWG logo, AutoCAD Map 3D, and Civil 3D are registered trademarks or trademarks of Autodesk, Inc., and/or its subsidiaries and/or affiliates in the USA and other countries. All other trademarks are the property of their respective owners.

Published in the United States of America by:

CADapult Press, Inc.

(503) 829-8929

books@cadapult-software.com

Printed and manufactured in the United States of America

About the Author

Rick Ellis has worked with and taught Autodesk Civil 3D, along with Map 3D and other Autodesk products since the mid-90s. He is the Author of several critically acclaimed books on Autodesk Civil 3D, Map 3D and Land Desktop.

Rick continues to use Autodesk Civil 3D on projects in a production environment, in addition to teaching classes to organizations both large and small.

This practical background and approach has made him an award winning speaker at Autodesk University, a member of the national speaker team for the AUGI CAD Camps and a sought after instructor by organizations around the world.

Rick can be reached at: rick@cadapult-software.com

About the Technical Editor

Russell Martin is an independent consultant who has worked with AutoCAD since 1985. He pioneered the position of Staff Geographer, and later served as CAD/GIS Manager at a multi-disciplinary engineering consulting firm. Russell has served as technical editor for many of Cadapult Press training books, and has co-authored and contributed to several other books on CAD, GIS and technical graphics software.

Russell can be reached at: russell@cadapult-software.com

Exercise Data

I would like to thank the City of Springfield, Oregon for providing the data for this book. The dataset provided is for illustration purposes only. While it is based on real world information to add relevance to the exercises, it has been altered and modified to more effectively demonstrate certain features as well as to protect all parties involved. The data should not be used for any project work and may not represent actual places or things. It is prohibited to redistribute this data beyond your personal use as a component of training.

A Practical Guide to Autodesk Civil 3D 2020

Introduction

Congratulations on choosing this course to help you learn how to use Autodesk Civil 3D 2020. The term “practical” is used in the title because this course focuses on what you need to effectively use Autodesk Civil 3D 2020 and does not complicate your learning experience with unnecessary details of every feature in the product. Should you want to pursue aspects of features and functionality in greater detail than provided in this course, you are directed and guided to that information.

Each lesson contains the concepts and principles of each feature to provide you with the background and foundation of knowledge that you need to complete the lesson. You then work through real world exercises to reinforce your understanding and provide you with practice on common tasks that other professionals are performing with Autodesk Civil 3D 2020 in the workplace every day.

You can take the lessons in this course in whatever order is appropriate for your personal needs. If you want to concentrate on specific features, the lesson for those features does not require that you complete prior lessons. With this course organization, you can customize your own individual approach to learning Autodesk Civil 3D.

When you complete this course, you will be armed with the background and knowledge to apply Autodesk Civil 3D to your job tasks, and become more effective and productive in your job.

Course Objectives

The objectives of this course are performance based. In other words, once you have completed the course, you will be able to perform each objective listed. If you are already familiar with Autodesk Civil 3D, you will be able to analyze your existing workflows, and make changes to improve your performance based on the tools and features that you learn and practice in this course.

After completing this course, you will be able to:

- Understand and work with Object Styles.
- Create, manage and apply Label Styles.
- Import and manage Points, and work with Point Groups.
- Create and edit Alignments.
- Define Parcels.
- Create and edit Profiles and Profile Views.
- Create Corridors and extract information from them.
- Sample Sections and plot Section Views.
- Import and leverage GIS Data in your Civil 3D projects.
- Use Queries to manage and share data.
- Layout Pipe Networks and edit them in plan and profile.
- Layout Pressure Networks and edit them in plan and profile.
- Create Sheets with the Plan Production tools.
- Work with the Grading tools.
- Create reports for Civil 3D objects.
- Calculate Volumes.
- Share project data with Data Shortcuts.

Prerequisites

Before starting this course, you should have a basic working knowledge of AutoCAD. A deep understanding of AutoCAD is not required, but you should be able to:

- Pan and Zoom in the AutoCAD drawing screen.
- Describe what layers are in AutoCAD, and change the current layer.
- Create basic CAD geometry, such as lines, polylines and circles.
- Use Object Snaps.
- Describe what blocks are, and how to insert them.
- Perform basic CAD editing functions such as Erase, Copy, and Move.

If you are not familiar with these functions, you can refer to the AutoCAD Help system throughout the course to gain the fundamental skills needed to complete the exercises.

Conventions

The course uses the following icons and formatting to draw your attention to guidelines that increase your effectiveness in Autodesk Civil 3D, or provide deeper insight into a subject.



The magnifying glass indicates that this text provides deeper insights into the subject.



The compass indicates that this text provides guidance that is based on the experience of other users of Autodesk Civil 3D. This guidance is often in the form of how to perform a task more efficiently.

Downloading and Installing the Datasets

In order to perform the exercises in this book, you must download a zip file and install the datasets.

Type the address below into your web browser to load the page where you can download the dataset.

www.cadapult-software.com/data

If you are using a previous version of Civil 3D you can download previous versions of the dataset to use with this book.

Unzip the Files

Unzip the file **APG_C3D2020.zip** directly to the C drive. The zip file will create the following folder structure:

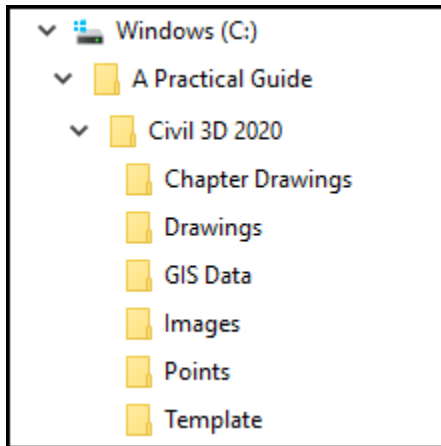

A folder called *Chapter Drawings* is created that contains a drawing that can be used to begin each exercise. This will allow you to jump in at the beginning of any exercise in the book, and do just the specific exercises that you want, if you do not have time to work through the book from cover to cover. The drawings in the Chapter Drawings folder are not necessary and only need to be used if you want to start in the middle of the book, or if you want to overwrite any mistakes that you may have made in previous chapters.

Three drawing templates called *_Practical Guide Training by Style.dwt*, *_Practical Guide Plan & Profile.dwt* and *_Practical Guide Section.dwt* are also available in the template folder.

Exercises

The exercises in this course have been designed to represent common tasks that are performed by civil engineers, surveyors, designers and drafters. The data included in the exercises are typical drawings, point files and other data used by professionals like you. You work with drawings, point files, aerial photos, GIS data, and much more; as you work through a road design project that also includes a sewer extension and detention pond.

Exercises provide higher level process information throughout the exercise tasks. You are given information about not only what to do, but why you are doing it. In most cases, an image is included to help guide you.

Table of Contents

Chapter 1	Autodesk Civil 3D User Interface	1
1.1	Lesson: Navigating the Autodesk Civil 3D User Interface	2
1.1.1	Navigating the Autodesk Civil 3D Interface	11
1.2	Lesson: Project Overview	14
Chapter 2	Data Collection and Base Map Preparation	17
2.1	Lesson: Importing GIS Data.....	18
2.1.1	Importing ESRI Shapefiles	21
2.1.2	Controlling the Display of Polygons.....	27
2.1.3	Viewing GIS Attributes in AutoCAD.....	28
2.1.4	Inserting a Registered Image (Rectified Aerial Photography).....	28
2.1.5	Assigning a Coordinate System to the Drawing	31
2.1.6	Adding an Online Map	33
2.1.7	Adding the Project Area.....	35
2.2	Lesson: Using Queries to Manage and Share Data	37
2.2.1	Attaching Source Drawings	44
2.2.2	Defining a Query.....	47
2.2.3	Saving Changes Back To the Source Drawings	49
2.2.4	Defining a Compound Query	51
Chapter 3	Preliminary Layout.....	59
3.1	Lesson: Creating a Preliminary Existing Ground Surface.....	60
3.1.1	Creating a Surface.....	63
3.1.2	Adding Surface Data	65
3.1.3	Changing the Surface Style to Control Display	68
3.1.4	Managing Drawing Settings.....	70
3.1.5	Using the Object Viewer	71
3.2	Lesson: Creating a Preliminary Alignment.....	72
3.2.1	Drafting the Preliminary Alignment Using Transparent Commands	74
3.3	Lesson: Creating Points from an Alignment.....	77
3.3.1	Establishing the Point Settings	80
3.3.2	Setting Points on an Alignment	82
3.3.3	Creating a Point Group.....	84
3.3.4	Creating a Point Import/Export Format.....	85
3.3.5	Exporting Points to an ASCII File	88

Chapter 4	Creating a Survey Plan	89
4.1	Lesson: Importing Survey Points.....	90
4.1.1	Creating a Description Key Set.....	93
4.1.2	Importing Points from an ASCII File.....	96
4.1.3	Confirming the Description Keys Worked Properly.....	97
4.2	Lesson: Working with Point Groups	98
4.2.1	Locking Points and Group Properties	101
4.2.2	Creating a Point Group for Property Corners	102
4.2.3	Creating a Point Group for Center Line Points	104
4.2.4	Creating a Point Group for Breakline Points.....	104
4.2.5	Creating a Point Group for Tree Points.....	105
4.3	Lesson: Controlling Point Display.....	106
4.3.1	Creating Point Styles.....	111
4.3.2	Creating Point Label Styles.....	114
4.3.3	Controlling Point Display with Point Groups	123
4.3.4	Controlling the Dragged State.....	124
4.3.5	Controlling Point Label Size in Model Space	125
4.3.6	Controlling Point Group Display Order.....	126
4.4	Lesson: Drawing Linework Using Transparent Commands	127
4.4.1	Drawing Lines by Point Number	130
4.4.2	Drawing Lines by a Range of Point Numbers.....	131
4.4.3	Drawing Lines by Point Object.....	132
4.5	Lesson: Working with Parcels	134
4.5.1	Defining a Parcel from Existing Geometry.....	136
4.5.2	Creating a Parcel Area Report.....	139
4.5.3	Creating a Parcel Legal Description Report	140
4.6	Lesson: Labeling Linework	142
4.6.1	Labeling Parcel Lines.....	145
4.6.2	Working with Parcel Segment Labels	147
4.6.3	Creating a Line Table.....	147
4.6.4	Creating a Parcel Area Table.....	150
4.6.5	Labeling AutoCAD Objects	157
Chapter 5	Building a Survey Quality Surface.....	161
5.1	Lesson: Building Surfaces from Survey Data.....	162
5.1.1	Creating a Point Group to Be Used As Surface Data	167
5.1.2	Creating the Survey Surface.....	168
5.1.3	Adding Point Group Data to a Surface.....	168

5.1.4	Creating Breaklines by Point Number	169
5.1.5	Creating Breaklines by Point Selection	170
5.1.6	Adding Breaklines to the Surface	172
5.1.7	Viewing the Surface.....	173
5.2	Lesson: Editing Surfaces	174
5.2.1	Editing Point Data	177
5.2.2	Editing Breaklines	178
5.2.3	Deleting Lines	179
5.2.4	Pasting Surfaces	181
5.3	Lesson: Surface Analysis.....	183
5.3.1	Displaying Slope Arrows.....	185
5.3.2	Elevation Banding.....	186
5.3.3	Slope Analysis	191
5.4	Lesson: Working with Contours	195
5.4.1	Displaying a Surface as Contours	197
5.4.2	Creating a Surface Style to Display Contours	198
5.4.3	Controlling Contour Display	201
5.4.4	Labeling Contours	202
5.4.5	Moving Contour Labels.....	203
5.4.6	Deleting Contour Labels	203
5.4.7	Labeling Only the Major Contours	204
5.4.8	Editing Contour Labels	205
5.4.9	Controlling Surface Display for Performance	208
Chapter 6	Working with Alignments and Parcels.....	209
6.1	Lesson: Creating Alignments	210
6.1.1	Default Curve Settings.....	212
6.1.2	Creating Tangents with Curves	214
6.2	Lesson: Editing Alignments.....	216
6.2.1	Editing Alignments Graphically.....	218
6.2.2	Editing Alignments in Grid View	218
6.3	Lesson: Working with Alignment Labels	220
6.3.1	Working with Alignment Station Labels	224
6.3.2	Changing the Stationing of an Alignment.....	225
6.3.3	Labeling Station and Offset Values	226
6.3.4	Creating Polyline Offsets of an Alignment.....	227
6.3.5	Creating Offset Alignments.....	228

6.4 Lesson: Laying Out Parcels.....	229
6.4.1 Merging Parcels	232
6.4.2 Creating Parcels Manually	232
6.4.3 Creating Parcels with the Slide Line Tool	234
6.4.4 Creating Parcels with the Slide Line Tool Automatically.....	236
6.4.5 Editing Parcels	238
6.4.6 Deleting Parcels	239
6.4.7 Renumbering Parcels.....	239
6.5 Lesson: Working with Parcel Styles and Labels.....	241
6.5.1 Controlling Parcel Display	244
6.5.2 Creating Parcel Styles.....	245
6.5.3 Creating Parcel Area Label Styles	249
6.5.4 Changing the Styles of Multiple Parcels	253
Chapter 7 Working with Profiles	255
7.1 Lesson: Creating Existing Ground Profiles.....	256
7.1.1 Sampling and Drawing the Profile.....	259
7.1.2 Changing the Profile View Style.....	266
7.1.3 Creating a Profile View Style	267
7.1.4 Creating Additional Profile Views	274
7.2 Lesson: Creating Finished Ground Profiles.....	276
7.2.1 Constructing the Finished Ground Centerline.....	280
7.2.2 Editing the Profile Graphically.....	282
7.2.3 Editing the Profile in Grid View	283
7.2.4 Working with Profile Labels.....	284
7.2.5 Adding Profile Labels	286
7.2.6 Working with Profile View Bands	287
7.2.7 Adding Profile View Bands.....	288
Chapter 8 Corridor Modeling	291
8.1 Lesson: Working with Assemblies	292
8.1.1 Creating an Assembly.....	294
8.2 Lesson: Working with Corridors.....	300
8.2.1 Creating a Corridor.....	303
8.2.2 Editing a Corridor	306
8.2.3 Creating Corridor Surfaces	308
8.2.4 Viewing and Editing Corridor Sections.....	310
8.2.5 Exporting Corridor Points	311

8.3 Lesson: Working with Sections	314
8.3.1 Creating Sample Lines	317
8.3.2 Creating a Section Group Plot Style.....	319
8.3.3 Creating Section Views	322
8.3.4 Creating Section Sheets.....	328
8.3.5 Volume Calculations	329
8.3.6 Creating a Mass Haul Diagram	330
8.3.7 Editing a Corridor to Update Surfaces, Sections, and Volumes.....	334
8.3.8 Creating a Surface Showing Final Site Conditions	334
8.4 Lesson: Plan Production	337
8.4.1 Creating View Frames	340
8.4.2 Editing View Frames.....	346
8.4.3 Editing Match Lines	346
8.4.4 Creating Plan and Profile Sheets	347
Chapter 9 Pipes.....	351
9.1 Lesson: Working with Pipe Networks in Plan.....	352
9.1.1 Laying Out a Pipe Network.....	355
9.1.2 Editing a Pipe Network in Plan	357
9.2 Lesson: Working with Pipe Networks in Profile	358
9.2.1 Adding a Pipe Network to a Profile.....	360
9.2.2 Editing a Pipe Network in Profile	361
9.2.3 Labeling a Pipe Network in Profile	362
9.3 Lesson: Working with Pressure Networks in Plan	363
9.3.1 Laying Out a Pressure Network	365
9.3.2 Adding a Lateral to a Pressure Network.....	368
9.4 Lesson: Working with Pressure Networks in Profile	370
9.4.1 Creating a Profile View with a Pressure Network.....	373
9.4.2 Editing a Pressure Network in Profile	376
Chapter 10 Grading	379
10.1 Lesson: Working with Grading Groups	380
10.1.1 Creating a Grading Group	383
10.1.2 Creating a Grading Object.....	385
10.1.3 Creating a Grading Infill.....	390
10.1.4 Reviewing Grading Group Properties.....	391
10.1.5 Calculating Stage Storage.....	393

10.2 Lesson: Volume Calculations	396
10.2.1 Creating a Grid Volume Surface	399
10.2.2 Creating a TIN Volume Surface	402
10.2.3 Displaying Cut and Fill with Surface Styles.....	403
10.2.4 Creating a Legend for Cut and Fill Depths	405
Chapter 11 Data Shortcuts	407
11.1 Lesson: Sharing Project Data with Data Shortcuts	408
11.1.1 Setting the Working Folder	413
11.1.2 Creating a Data Shortcut Project	414
11.1.3 Creating Data Shortcuts.....	415
11.1.4 Creating Data Shortcut References	416

Sample Lesson

5.1 Lesson: Building Surfaces from Survey Data

Introduction

Any time you build a surface the most important step is to understand what data you have available to work with. In this chapter, you will work with points that will be managed with a *Point Group* and breaklines that you will create based on some of those same survey points.

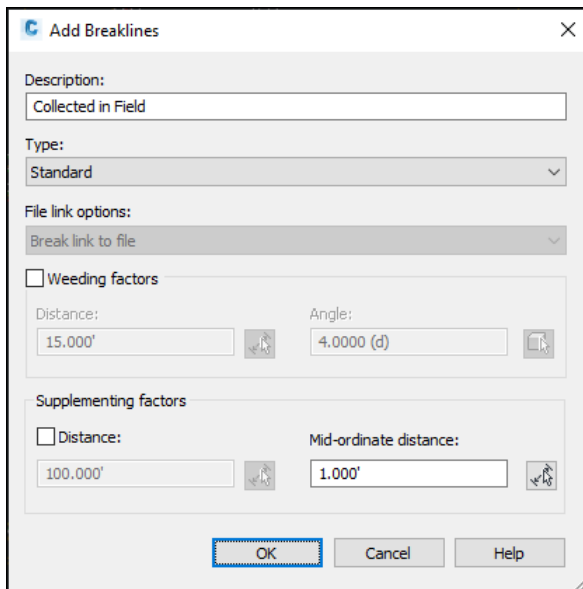

Key Concepts

Concepts and key terms covered in this lesson are:

- Surface
- Points
- Point Group
- Breaklines
- Surface Styles

Objectives

After completing this lesson, you will be able to:

- Create a Point Group for use building a Surface
- List the types of data that can be used to build a Surface.
- Describe what a breakline is.
- Draw and define breaklines.

Types of Surface Data

Surfaces can be built from a combination of many different types of data:

- Boundaries
- Breaklines
- Contours
- DEM files (Digital Elevation Models)
- Drawing Objects
- Point Files
- Point Groups
- Point Survey Queries
- Figure Survey Queries

Boundaries

A boundary is a closed polygon that limits the triangulation of a surface.

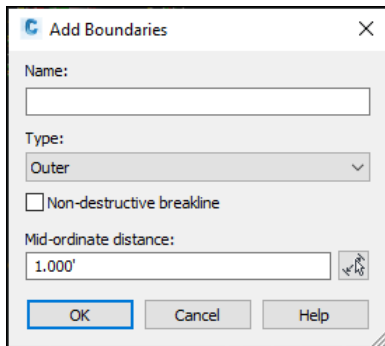

Boundary Types:

- Outer
 - Defines the outer boundary of a surface
 - Triangles outside of this boundary are removed
- Show
 - Displays the triangles inside the boundary
 - Can be used inside of a Hide boundary
- Hide
 - Removes triangles inside of the boundary
 - Creates a hole in the surface
 - Can be used for building footprints to keep contours from crossing through them
- Data Clip
 - Keeps data outside this boundary from being added to the surface
 - Must be added before other surface data or moved up in priority in the surface definition
 - Useful for limiting the size of large datasets

Non-destructive breakline boundaries

Outer, Show and Hide boundaries have the option to be created as non-destructive breaklines. When this option is enabled it trims the TIN lines at the boundary. When it is not used it erases all the TIN lines that touch the boundary.

This can be a good option if you have good surface data on each side of the boundary as it will cut a clean and straight boundary through the surface. However, if this option is used on an outer boundary where all of the surface data is inside the boundary and the only triangle touching it are long and inaccurate, then you may be left with short triangles along the edge that are still at the wrong slope.

Breaklines

Breaklines define grade breaks in a surface. They are lines in a TIN that represents a distinct interruption in the slope of a surface; like road centerlines, curbs, gutters, streams, tops and toes of slopes, or any other grade break. No triangle in a TIN may cross a breakline (in other words, breaklines are enforced as triangle edges).

Types of breaklines:

- Standard
 - Defined by selecting 3D polylines, 3D lines, feature lines, or splines
- Proximity
 - Defined by selecting a 2D polyline, feature line or spline
 - The vertices of the breakline are snapped to the nearest point in the TIN, or closest proximity
 - Accuracy is dependent on how close the vertices of the proximity breakline are to the points in the TIN
 - Can be very accurate and efficient if you have drawn the selected object from point to point
- Wall
 - Defined by selecting 3D polylines, 3D lines, feature lines, splines or by selecting points.
 - You enter the elevation on each side of the wall at each vertex
- From file
 - Can be imported from an ASCII FLT file
- Non-destructive
 - Break the triangles in the TIN without changing the slope of the lines

Contours

Contour data in the form of 2D polylines can be added to your surface.

Weeding factors can help you skip over extra, unnecessary vertices when the data is added to the surface. While supplementing factors will allow you to sample extra points off long contours with minimal vertices.

Since by its nature, contour data tends to create flat triangles that do not accurately reflect the surface, there are several options to minimize those flat triangles. In most cases it is a best practice to enable all four options to minimize flat areas when adding contour data to a surface.

DEM Files

DEM files (Digital Elevation Models) are grid based surfaces. This is a format that is used by many different Civil, Survey, and GIS programs.



DEM files are a format that is commonly used by the USGS and there is a tremendous amount of data that is available online for free in this format.

Drawing Objects

AutoCAD object that have elevations can be used to build a surface. These objects include:

- Points
- Lines
- Blocks
- Text
- 3D Faces
- Polyface

Point Files

ASCII point files can be imported directly into the surface. This is a good option for large datasets or points that you do not need in the drawing for anything other than building a surface.

Point Groups

Point groups can be used to add a specific selection set of points to a surface. It may be common that some of the points in your drawing are not related to a surface. For example, you would not want to include a point representing the invert of a manhole in the surface. A point group consisting of only surface related points is an efficient way to add only the appropriate points to the surface.

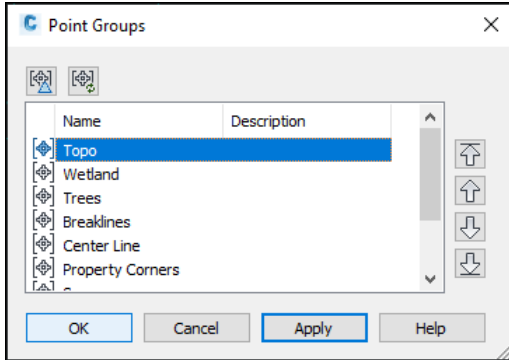

Point Survey Queries

Point Survey Queries are a dynamic reference to a selection of survey points that are included in a survey database. If the points in the survey database are updated, the surface will be marked as out of date and will use the updated values when it is rebuilt.

Figure Survey Queries

Figure Survey Queries are a dynamic reference to a selection of survey figures that are included in a survey database. If the figures in the survey database are updated, the surface will be marked as out of date and will use the updated values when it is rebuilt.

Exercises: Build a Surface from Survey Data

In these exercises, you create a new surface from point group data. You will draw breaklines from survey points and add them to the surface. Then you will view the surface in the Object Viewer to examine it in 3D from different angles.

You do the following:

- Create a Point Group of surface related points.
- Create a Surface.
- Draw Breaklines.
- Add Breaklines to the Surface.
- View the Surface in 3D using the Object Viewer.

5.1.1 Creating a Point Group to Be Used As Surface Data

Before you create the surface you need to create a *Point Group* that will be used to select only the points that you want to use for the surface data. Points that should not be included in the surface should not be included in the point group. Points for utility potholes or points that are part of the project for horizontal control and do not have accurate surface elevations are examples of points that should not be included in this group.

1. Continue working in the drawing **Design.dwg**.

This drawing contains the *Points*, *Alignment*, *Parcels*, and *Surface* from the previous chapters. Currently only the parcel lines and labels are displayed.

Reminder: You can also open the drawing with this exercise number in the *Chapter Drawings* folder of the dataset if you prefer a fresh start at this point.

2. On the *Prospector* tab of the *Toolspace*, right-click on **Point Groups** and select ⇒ **New**.
3. Enter **Topo** for the **Name**.
4. Select the **Raw Desc Matching** tab in the *Point Group Properties dialog box*.

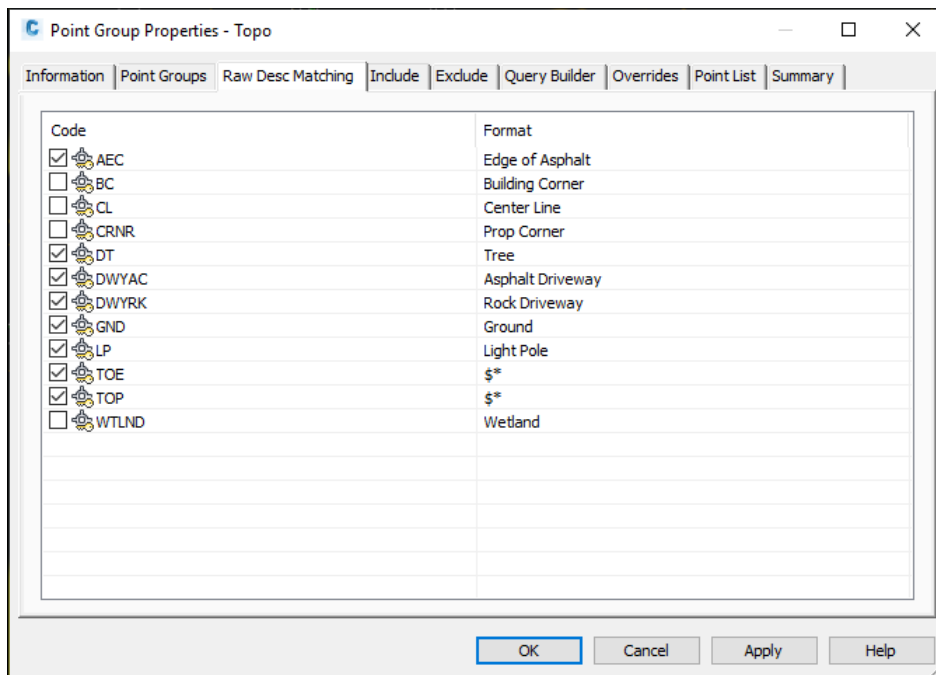

5. Select the description keys **AEC**, **DT**, **DWYRK**, **DWYAC**, **GND**, **LP**, **TOE**, and **TOP**.
6. Click <<**OK**>> to create the *Point Group*.

5.1.2 Creating the Survey Surface

1. On the *Prospector* tab of the *Toolspace*, right-click on **Surfaces** and select ⇒ **Create Surface**.
2. Confirm that **TIN surface** is selected as **Type**.
3. Enter **Survey** for the **Name**.
4. Set the **Style** to **Border & Contours**.
5. Confirm the *Surface layer* is set to **C-TOPO-Survey**.

This layer name that includes the surface name as a suffix was setup in an earlier exercise through the Drawing Settings command.

6. Click <<**OK**>> to close the *Create Surface* dialog box and create the surface.

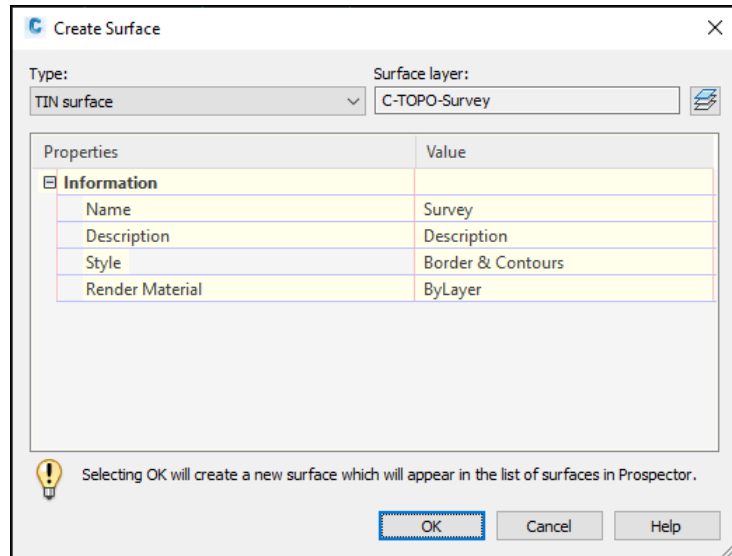

At this time the surface has not been given any data so it is not displayed. However, it has been created and you will see it in the *Prospector*. This is where you will access the surface definition commands and add data to the surface.

5.1.3 Adding Point Group Data to a Surface

Point information contained in a *Point Group* can be added to a *Surface* through the *Prospector*. Once the *Point Group* is added the *Surface* is automatically rebuilt to incorporate and display the new data.

1. On the *Prospector* tab of the *Toolspace*, expand **Surfaces**.
2. Expand the *Surface Survey*.
3. Expand the **Definition** node under *Survey*.
4. Right-click on **Point Groups** under *Definition* and select ⇒ **Add**.
5. Select the *Point Group Topo*.
6. Click <<**OK**>> to add the point group data to the surface.

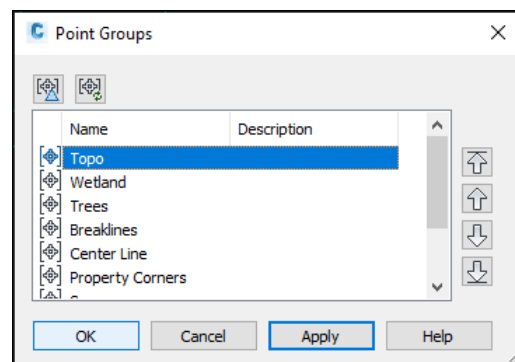

The surface is built with the point group data and displays 5 foot contours colored brown and green with a yellow border. This display is controlled by the surface style you selected when you created the surface. If the surface is not visible turn on and thaw the layer *C-TOPO-Survey*.

5.1.4 Creating Breaklines by Point Number

Civil 3D does not use special commands for drawing and defining breaklines the way that *Land Desktop* and many other programs do. Instead, you draw the breaklines with standard *AutoCAD* commands, like the *3D Polyline* command, and then define these objects as breaklines after they have been drawn.

1. Create a new *Layer* named **Breaklines-Survey** and set it **Current**.
2. Thaw the layers **PNTS-AEC**, **PNTS-BREAK**, and **PNTS-DRIVEWAY**.
3. Freeze the layers **C-ANNO**, **C-PROP**, **C-PROP-LINE**, **C-PROP-TABL**, **EX-WETLAND-LINE**, and **PNTS-WTLND**.

The drawing will now display the surface as contours and points that you will use for breaklines. You may need to *Regen* to clean up the display.

4. Enter **3P** at the command line to start the **3D Polyline** command.
5. Enter **'PN** to change the prompt to **Point Number**.

Alternatively, you can also select the *Point Number* button  from the *Transparent Commands* toolbar.

6. At the command line enter: **1408-1447** and **[Enter]** to draw the line.
7. **[Esc]** to end the Point Number prompt.
8. **[Enter]** to end the line.
9. Enter **3P** at the command line to start the **3D Polyline** command.

10. Use the points in the following list of points to draw the breaklines the same way that you drew the previous line. Be sure to use the **Point Number** transparent command to change the prompt to Point Number and to end the command completely after drawing each line. Also be sure to **[Enter]** after each non-sequential point number as shown below in the list.

Point Numbers

1448-1486
1008-1021
1191-1209
1226-1257
1258-1278
1281-1324
1295 [Enter] 1661-1710
1622-1660 [Enter] 1294
1286 [Enter] 1348-1398 [Enter] 1287
1022-1074
1075-1105
1155-1158
1159-1160
1153-1154
1143-1151
1130-1142
1121-1129

The new *3D Polylines* will look like the graphic below. However, they have not yet been added to the surface as breaklines.

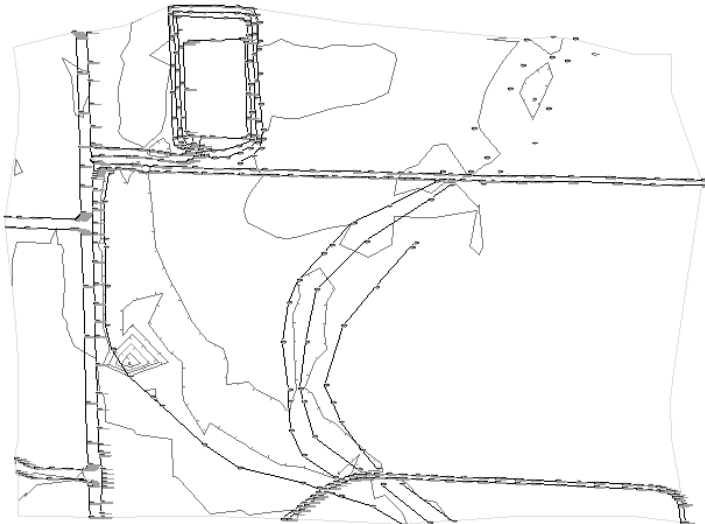

5.1.5 Creating Breaklines by Point Selection

1. On the *Prospector* tab of the *Toolspace*, select the *Point Group Breaklines*.

This will display a list of all the points used in the surface in the preview window at the bottom of the *Prospector*, if the *Prospector* is docked. If the *Prospector* is not docked it will display on the side.

2. Find point number **1110** in the preview window.

3. Right-click on point **1110** and select **Zoom to**. You may want to zoom out some to see the surrounding points.
4. Enter **3P** at the command line to start the **3D Polyline** command.
5. Enter **'PO** to change the prompt to **Point Object**.

Alternatively, you can also select the *Point Object* button  from the *Transparent Commands* toolbar.

6. Pick point **1110** from the screen.
7. Then pick points **1109, 1108, 1107, and 1106** to draw a breakline between the TOP points toward the northeast corner of the site.

When using the *Point Object* transparent command to draw lines between point objects you will not see the rubber band line that you normally see with the line command.

8. **[Enter]** to end the **Point Object** prompt.
9. **[Enter]** again to end the line.
10. Starting at point **1116**, define a second breakline along the bottom of the ditch using the **3D Polyline** command with the **'PO** transparent command and points **1116, 1117, 1118, 1119, and 1120**.
11. **[Enter]** to end the Point Object prompt.
12. **[Enter]** again to end the line.
13. Starting at point **1111**, define a third breakline along the bank of the ditch using the **3D Polyline** command with the **'PO** transparent command and points **1111, 1112, 1113, 1114, and 1115**.
14. **[Enter]** to end the Point Object prompt.
15. **[Enter]** again to end the line.
16. Save the drawing.

The three new *3D Polylines* will look like the graphic below. However, they have not yet been added to the surface as breaklines.

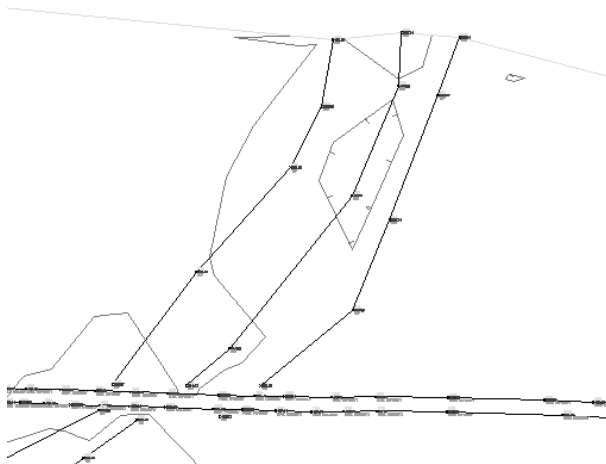

5.1.6 Adding Breaklines to the Surface

1. Select **Ribbon: Home ⇒ Layers ⇒ Isolate**.

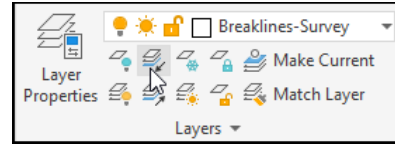

2. Pick one of the breaklines and one of the contours from the surface to isolate the **Breaklines-Survey** and **C-TOPO-Survey** layers.
3. Confirm that the **Definition** under the **Surface Survey** is expanded on the *Prospector* tab of the *Toolspace*.
4. Right-click on **Breaklines** under the **Definition** and select ⇒ **Add**.
5. Enter a **Description** for the breakline set of **Collected in Field**.
6. Confirm that the **Type** is set to **Standard**.

You will not use any *Weeding* or *Supplementing factors* in this exercise. These options allow you to remove or add vertices to breaklines respectively. These are useful options if you have breaklines that have been over digitized and may have thousands of extra vertices very close together or if you need to add vertices to a breakline that has long distances between vertices.

7. Click **<<OK>>**.

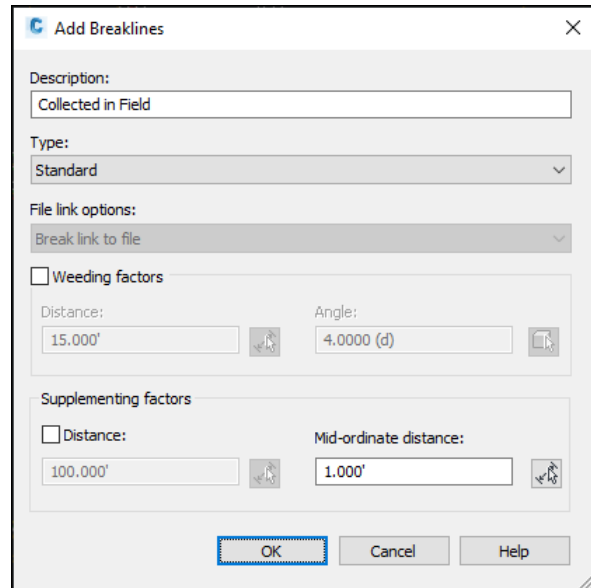

8. Select the **Breaklines** with a crossing window.
9. **[Enter]** to add the breaklines to the surface.

The surface is now updated to include the new breakline data.

10. Select **Ribbon: Home ⇒ Layers ⇒ Unisolate** to restore the previous layer state.

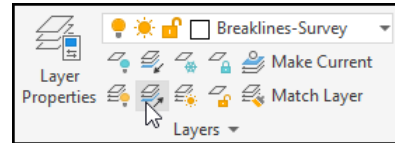

11. Save the drawing.

5.1.7 Viewing the Surface

The Object Viewer is a separate window that will allow you to view a selected object or objects in 3D and rotate them in real-time.

1. Pick one of the **contours** to highlight the entire surface.
2. **Right-click** and select ⇒ **Object Viewer**.
3. In the **Object Viewer**, click and drag while holding down the left mouse button to rotate the surface in 3D.

Once you rotate to a 3D view the contours will change to 3D faces. This is controlled by the surface object style.

4. If the surface is not shaded right-click and select **Visual Styles** ⇒ **Shades of Gray**.
5. Continue to rotate the surface to examine it from different angles. You will notice a large hole, or spike, in the surface.

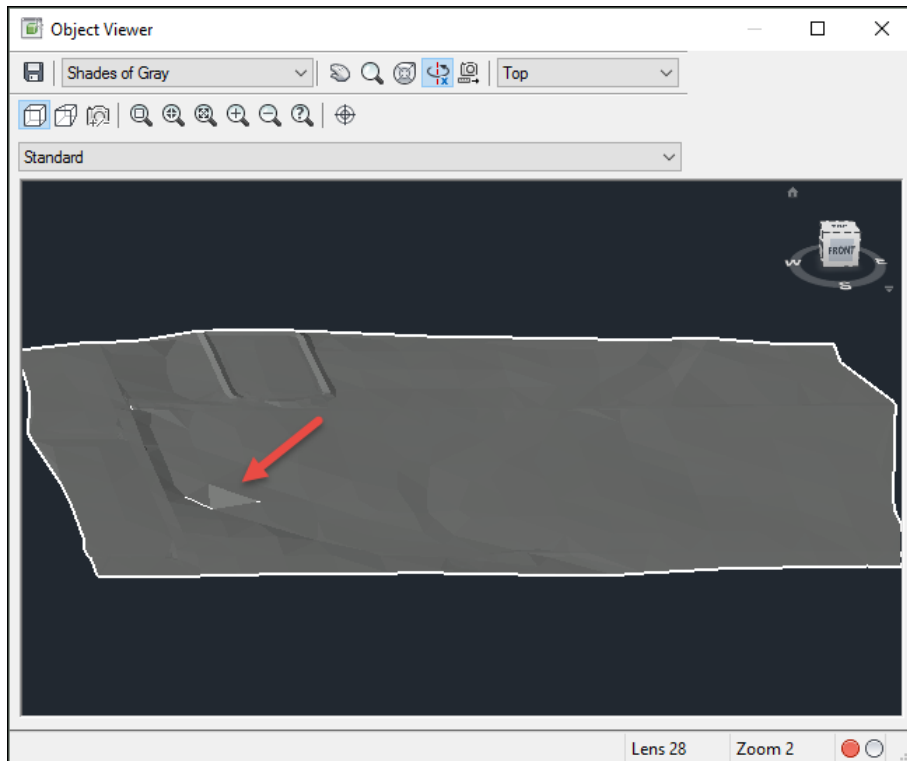

6. When you are finished viewing the surface close the object viewer window to return to the drawing editor. You should also be able to identify this hole by looking at the contours in plan view.

In the next lesson, you will learn to edit the surface to fix this and other errors.

Index

Alignment	73, 211	Labeling Parcel Segments	143
Alignment Editing	217	Layout Profiles	257, 277
Alignment Label Sets	221	Legal Description	136
alignment label styles	221	Location Queries	40
Alignment Layout	211	Locking Point Groups	99
appurtenances	364	Locking Points	99
ASCII File	92	Map Explorer	7
Assemblies	293	Map Import	19, 20
Baselines	301	Mass Haul Diagrams	316
Boundaries	163	Match Line	339
Breaklines	164	Meets and Bounds	136
Capture Area	34	Multiple Parcel Properties	243
Command Line	9	Network Parts List	353, 364
Compound Queries	42	Object Data	20
Contextual Ribbons	3	Offset Alignments	223
Contours	165, 196	Online Map	33
Coordinate system	31	Parcel Area Label Styles	242
Coordinate System	19	Parcel Area Labels	136
Corridor	301	Parcel Editing	230
Corridor Surfaces	302	Parcel Layout Tools	231
Cut and Fill Depths	398	Parcel Reports	136
Data Shortcuts	409	Parcel Segment Label Styles	243
Data Shortcuts Project Folder	411	Parcel Styles	242
Delete PI	217	Parcels	135, 230
DEM Files	165	Paste Surface	175
Description Keys	91	Pipe Network Layout Tools	354, 365
Display Manager	7	Pipe Network Profiles - Projected	359, 372
Drafting Settings	9	Pipe Networks	353, 364
Editing Surfaces	175	Pipe Networks in Profile	359, 371
Elevation Banding	184	pipes	353, 364
External References	409	Plan Production Tools	337
fittings	364	Point	78
Frequency	302	Point Files	166
GIS Data	19	Point Group	79
Grading Criteria	381	Point Group Display Order	109
Grading Groups	381	Point Groups	99, 166
grading objects	381	Point Import/Export formats	80
Grading Tools	382	Point Label Style	78
Grid Volume Surfaces	397	Point Label Styles	108
Import Attributes	19	Point Settings	79
Import Coordinate Systems	19	Point Style	78
Import Geometry	19	Point Styles	107
Import Interface	20	Pressure Network Layout	365
Import Spatial Filters	19	Pressure Network Parts List	364
Importing Points	92	Pressure Networks	364
Insert PI	217	pressure pipes	364
Inverse	136	Profile Editing	277
Labeling AutoCAD Objects	144	Profile Label Sets	278
Labeling Contours	196	profile label styles	278

Profile Layout Tools	277	Subassemblies	293
Profile View Bands	279	Surface	61
Profile View Styles	258	Surface Analysis	184
Profile Views	258	Surface Data	163
Profiles	257	Surface Profiles	257
Property Queries	41	Surface Style	62
Query	38, 39	Surface Styles	196
Query Tools	40	Surveyors Certificate	136
Regions	301	Tables	144
Ribbon	3	Tags	143
Sample Line Groups	315	Targets	301
Sample Lines	315	Task Pane	7
Saved Queries	43	Task-Based Ribbon	8
Section Based Volumes	316	TIN Volume Surfaces	398
Section View Styles	316	Tool-Based Ribbon	8
Section Views	315	Transparent commands	73
Sites	135	Transparent Commands	128
Stage Storage	393	User Interface	1
Station and Offset Labels	222	View Frame	338
Stationing	222	Working Folder	410
structures	353, 364	Workspaces	8



A Practical Guide to GIS in Autodesk Civil 3D® 2020

Rick Ellis and Russell Martin



A CADapult Press Publication

Copyright

Copyright © CADapult Press, Inc. 2019

All rights reserved. No part of this publication may be reproduced in any form, or by any means electronic, mechanical, recording, photocopying, or otherwise, without written permission from the publisher, except for brief quotations used in reviews, or for marketing purposes specific to the promotion of this work.

ISBN: 978-1-934865-45-3

Although CADapult Press has made every attempt to ensure the accuracy of the contents of this book, the publisher and author make no representations or warranty with respect to accuracy or completeness of the contents in this book, including without limitation warranties of fitness for a particular purpose. The datasets included in this book are for training purposes only.

Autodesk screen shots reprinted with the permission of Autodesk, Inc.

Autodesk, AutoCAD, DWG, the DWG logo, Civil 3D and AutoCAD Map 3D are registered trademarks or trademarks of Autodesk, Inc., and/or its subsidiaries and/or affiliates in the USA and other countries. All other trademarks are the property of their respective owners.

Published in the United States of America by:

CADapult Press

(503) 829-8929

books@cadapult-software.com

Printed and manufactured in the United States of America

About the Authors

Rick Ellis has worked with and taught Autodesk Civil 3D, along with Map 3D and other Autodesk products since the mid-90s. He is the Author of several critically acclaimed books on Autodesk Civil 3D, Map 3D and Land Desktop.

Rick continues to use Autodesk Civil 3D on projects in a production environment, in addition to teaching classes to organizations both large and small.

This practical background and approach has made him an award winning speaker at Autodesk University, a member of the national speaker team for the AUGI CAD Camps and a sought after instructor by organizations around the world.

Rick can be reached at: rick@cadapult-software.com

Russell Martin is an independent consultant who has worked with CAD, GIS and cartographic design tools since 1985. He has taught AutoCAD and AutoCAD Map 3D in small classrooms and at large events such as Autodesk University. Russell has co-authored several books on AutoCAD Map 3D, and has served as technical editor of many other books on CAD, computer graphics, Land Desktop and Civil 3D.

Russell also performs design, production mapping and GIS analysis services for a diverse client base, both public and private. He uses AutoCAD, Map 3D and Civil 3D tools daily, to produce maps and graphics which clearly communicate complex quantitative data.

Russell can be reached at: russell.p.martin@gmail.com

Exercise Data

CADapult Press would like to thank the City of Springfield, Oregon for providing the data for this book. The dataset provided is for illustration purposes only. While it is based on real world information to add relevance to the exercises, it has been altered and modified to more effectively demonstrate certain features as well as to protect all parties involved. The data should not be used for any project work and may not represent actual places or things. It is prohibited to redistribute this data beyond your personal use as a component of training.

A Practical Guide to GIS in Autodesk Civil 3D 2020

Introduction

Congratulations on choosing this course to help you learn how to use GIS in Autodesk Civil 3D 2020. The term “practical” is used in the title because this course focuses on what you need to effectively use the GIS tools in Autodesk Civil 3D 2020, and does not complicate your learning experience with unnecessary details of every feature in the product. Should you want to pursue aspects of features and functionality in greater detail than provided in this course, you are directed and guided to that information.

Each lesson contains the concepts and principles of each feature to provide you with the background and foundation of knowledge that you need to complete the lesson. You then work through real world exercises to reinforce your understanding and provide you with practice on common tasks that other professionals are performing with Autodesk Civil 3D 2020 in the workplace every day.

You can take the lessons in this course in whatever order is appropriate for your personal needs. If you want to concentrate on specific features, the lesson for those features does not require that you complete prior lessons. With this course organization, you can customize your own individual approach to learning Autodesk Civil 3D.

When you complete this course, you will be armed with the background and knowledge to apply Autodesk Civil 3D to your job tasks, and become more effective and productive in your job.

Course Objectives

The objectives of this course are performance based. In other words, once you have completed the course, you will be able to perform each objective listed. If you are already familiar with Autodesk Civil 3D, you will be able to analyze your existing workflows, and make changes to improve your performance based on the tools and features that you learn and practice in this course.

After completing this course, you will be able to:

- Work with coordinate systems
- Clean drawings with common geometry errors
- Insert rectified raster images
- Work with a variety of attribute data
- Apply object classification to your mapping system
- Import GIS data from a variety of sources
- Create surfaces and pipe networks directly from GIS data
- Export geometry and attribute data to other GIS formats
- Export Civil 3D objects to other GIS formats
- Connect directly to GIS data
- Access Data using the Autodesk Connector for ArcGIS
- Connect to raster surface data
- Attach and query source drawings
- Save changes to attached source drawings
- Extract data for reports and quantity takeoffs
- Create, manage and analyze topologies
- Utilize Dynamic Viewport Tools
- Produce sophisticated map books

Prerequisites

Before starting this course, you should have a basic working knowledge of AutoCAD. A deep understanding of AutoCAD is not required, but you should be able to:

- Pan and Zoom in the AutoCAD drawing screen.
- Describe what layers are in AutoCAD, and change the current layer.
- Create basic CAD geometry, such as lines, polylines and circles.
- Use Object Snaps.
- Describe what blocks are, and how to insert them.
- Perform basic CAD editing functions such as Erase, Copy, and Move.

If you are not familiar with these functions, you can refer to the AutoCAD Help system throughout the course to gain the fundamental skills needed to complete the exercises.

Conventions

The course uses the following icons and formatting to draw your attention to guidelines that increase your effectiveness in Autodesk Civil 3D, or provide deeper insight into a subject.



The magnifying glass indicates that this text provides deeper insights into the subject.



The compass indicates that this text provides guidance that is based on the experience of other users of Autodesk Civil 3D. This guidance is often in the form of how to perform a task more efficiently.



The warning indicates that a specific exercise might not function properly on 64 bit operating systems.



The workspace icon indicates the Workspace that will be used in the upcoming exercise.

Downloading and Installing the Datasets

In order to perform the exercises in this book, you must download a zip file and install the datasets.

Type the address below into your web browser to load the page where you can download the dataset.

www.cadapult-software.com/data

If you are using a previous version of Civil 3D you can download a previous version of the dataset to use with this book.

Unzip the Files

Unzip the file **APG_GIS2020.zip** directly to the C drive. The zip file will create the following folder structure:

C:\A Practical Guide\GIS in Civil 3D 2020\Chapter Number\Files for Exercises

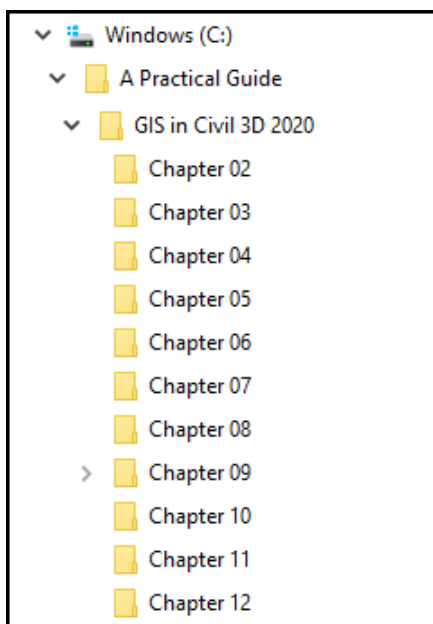

Exercises

The exercises in this course have been carefully chosen and designed to represent common tasks that are performed by mapping and GIS professionals. The data included in the exercises are typical drawings and maps used by local governments and municipalities. You work with road networks, parcel maps, sewer collection systems, water distribution systems, aerial photos, raster surfaces, and much more.

Exercises provide higher level process information throughout the exercise tasks. You are given information about not only what to do, but why you are doing it. In most cases, an image is included to help guide you.

64 Bit Database Drivers

On 64 bit systems, exercises that require a connection to an ODBC database need to have the proper drivers from Microsoft installed. If your system does not have these installed, you can download them from Microsoft. Go to [<http://www.microsoft.com>] and search for Microsoft Access Database Engine.

Be sure to download the 64 bit version of the Microsoft Access Database Engine. You do not need to have Microsoft Office installed to install these drivers or to complete the exercise in this book. However, if you have Microsoft Office installed it will need to be the 64 bit version of Office for the 64 bit drivers to install.

Table of Contents

Chapter 1	Autodesk Civil 3D User Interface for GIS	1
1.1	Exploring the Civil 3D Tools for GIS	2
1.1.1	Navigating the Civil 3D Interface for GIS.....	10
Chapter 2	Creating Map Geometry	13
2.1	Lesson: Establishing Coordinate Systems in Drawings.....	14
2.1.1	Assigning a Coordinate System	19
2.1.2	Coordinate Tracking	20
2.1.3	Digitizing Points	21
2.2	Lesson: Creating and Inquiring COGO Data	23
2.2.1	Drawing with Transparent Commands	26
2.2.2	Line and Arc Information	28
2.2.3	Angle Information	29
2.2.4	Continuous Distance	29
2.2.5	Continuous Distance from a Base Point.....	30
2.2.6	Add Distance	31
2.2.7	List Slope.....	31
2.3	Lesson: Using Drawing Cleanup.....	33
2.3.1	Break Crossing Objects.....	38
2.3.2	Extend Undershoots	42
2.3.3	Delete Duplicates	43
2.3.4	Zero Length Objects	45
2.3.5	Dissolve Pseudo Nodes	46
2.3.6	Simplifying Objects	47
Chapter 3	Working with Attribute Data.....	51
3.1	Lesson: Attribute Data Concepts	52
3.2	Lesson: Defining Object Data Tables	57
3.2.1	Creating Object Data Tables	61
3.3	Lesson: Attaching Object Data to Objects	66
3.3.1	Attaching Object Data to Objects	70
3.3.2	Attaching Object Data While Digitizing.....	72
3.4	Lesson: Editing Object Data and Object Data Tables	75
3.4.1	Editing Object Data.....	80
3.4.2	Editing Object Data Tables.....	82

3.5	Lesson: Attaching External Databases	84
3.5.1	Attaching External Databases.....	88
3.6	Lesson: Working with Data View	89
3.6.1	Navigating in the Data View Table.....	92
3.6.2	Applying SQL Filters	93
3.7	Lesson: Defining a Link Template and Generating Links.....	98
3.7.1	Defining a Link Template	104
3.7.2	Attaching Database Data to Existing Objects	105
3.7.3	Attaching Database Data While Digitizing	107
3.7.4	Generating Links to Existing Blocks.....	109
3.7.5	Highlighting objects by selecting records.....	110
3.7.6	Highlighting table records by selecting objects.....	112
3.7.7	Using Spatial Filters	113
3.8	Lesson: Establishing the Dynamic Annotation Environment.....	114
3.8.1	Defining an Annotation Template.....	118
3.9	Lesson: Inserting and Managing Dynamic Annotation	121
3.9.1	Annotating Objects.....	124
3.9.2	Annotating Multiple Values	125
3.9.3	Updating Annotation.....	128
3.9.4	Rotating Annotation to Align with Objects.....	129
3.9.5	Adding Text to Annotation Expressions	131
3.9.6	Adding the Inch Symbol ("")	132
3.9.7	Adding Length to the Annotation Template	133
3.9.8	Controlling Precision	135
Chapter 4	Object Classification	137
4.1	Lesson: Creating Object Classification Definition Files and Object Classes	138
4.1.1	Log in as SuperUser	143
4.1.2	Create a New Definition File	144
4.1.3	Define an Object Class	145
4.2	Lesson: Classifying Existing Objects and Validating Standards	150
4.2.1	Classifying Existing Objects.....	154
4.2.2	Validating Classified Objects	155
4.3	Lesson: Creating New Classified Objects	156
4.3.1	Creating New Classified Objects	158

Chapter 5	Importing and Exporting	161
5.1	Lesson: Importing GIS Data.....	162
5.1.1	Importing an ArcInfo Coverage	165
5.1.2	Importing Polygons from an ArcView Shapefile	170
5.1.3	Creating Centroids.....	175
5.2	Lesson: Exporting GIS Data	177
5.2.1	Exporting Polygons to a SHP file	181
5.2.2	Export to an SDF File	183
5.3	Importing GIS Data as Civil 3D Objects.....	187
5.3.1	Creating a Surface from a Shapefile	189
5.3.2	Creating a Pipe Network from a SHP	193
5.4	Exporting Civil 3D Objects as GIS Data.....	201
5.4.1	Exporting Civil 3D Objects to an SDF File.....	202
Chapter 6	Connecting to Feature Sources.....	205
6.1	Lesson: Feature Source Concepts	206
6.2	Lesson: Connecting to SDF and SHP.....	210
6.2.1	Connect to and Add SDF Data.....	214
6.2.2	Connect to and Add SHP Data.....	217
6.3	Lesson: Autodesk Connector for ArcGIS	220
6.3.1	Connect to ArcGIS.....	222
6.4	Lesson: Working with Feature Layers.....	227
6.4.1	Working with Feature Layers.....	231
6.5	Lesson: Connecting to ODBC Point Feature Sources.....	234
6.5.1	Create a System DSN	237
6.5.2	Connect to a DSN, and Add Points to a Map.....	239
Chapter 7	Using Raster Images in Maps	243
7.1	Lesson: Inserting Raster Images	244
7.1.1	Inserting a Correlated Image	249
7.2	Lesson: Managing Raster Images	251
7.2.1	Adjust Image Display Properties	254
7.2.2	Clipping Images.....	254
7.2.3	Adding an Online Map	256
7.3	Lesson: Connecting to Raster and Raster Surfaces.....	259
7.3.1	Connecting to an Aerial Photo.....	264
7.3.2	Connecting to a Raster Surface	266

Chapter 8	Stylizing Features	269
8.1	Lesson: Stylizing Lines, Points, and Polygons	270
8.1.1	Stylizing Polygon Features	275
8.1.2	Stylizing Line Features.....	279
8.1.3	Stylizing and Labeling Point Features.....	280
8.2	Lesson: Stylizing Raster Surfaces.....	283
8.2.1	Stylizing Raster Features	288
8.2.2	Creating Contours from a Raster Surface	290
8.3	Lesson: Creating Scale Dependent Styles	291
8.3.1	Working with Scale Dependent Styles	295
8.4	Lesson: Applying Themes to Feature Layers	298
8.4.1	Thematic Mapping of Linear Objects with Object Data.....	302
8.4.2	Thematic Mapping of Polygon Features	305
Chapter 9	Working with Features	307
9.1	Lesson: Creating Feature Filters and Feature Queries	308
9.1.1	Performing a Filter to Select	312
9.1.2	Performing a Feature Query	313
9.2	Lesson: Editing Feature Geometry and Attributes	315
9.2.1	Editing Features	320
9.3	Lesson: Creating Joins	324
9.3.1	Create a System DSN.....	329
9.3.2	Join Tables, and Create a Thematic Map	331
9.4	Lesson: Using Constraints.....	336
9.4.1	Working with Constraints	340
9.5	Lesson: Bulk Copy Between Feature Sources.....	344
9.5.1	Exporting an SHP to an SDF	348
9.5.2	Bulk Copy from an SDF to an SHP.....	349
Chapter 10	Using Attached Source Drawings and Queries.....	353
10.1	Lesson: Managing Source Drawings.....	354
10.1.1	Managing Source Drawings.....	360
10.2	Lesson: Executing Location and Property Queries	365
10.2.1	Executing Location Queries	372
10.2.2	Executing Property Queries	378
10.2.3	Executing Compound Queries	380
10.3	Lesson: Executing Data Queries	384
10.3.1	Query by Pipe Size from Object Data	387

10.4 Lesson: Altering Properties During Queries	392
10.4.1 Execute a Query with a Property Alteration	395
10.5 Lesson: Using Save-Back	398
10.5.1 Execute Save-Back to Save Changes to an Attached Source Drawing	404
10.6 Lesson: Working with Multiple Coordinate Systems.....	407
10.6.1 Working with Source Drawings in Multiple Coordinate Systems.....	410
Chapter 11 Working with Topologies	413
11.1 Lesson: Creating Network Topologies	414
11.1.1 Creating a Network Topology	419
11.2 Lesson: Creating Polygon Topologies	423
11.2.1 Creating a Polygon Topology	427
11.3 Lesson: Performing Topology Analysis.....	433
11.3.1 Network Analysis	437
11.3.2 Performing a Buffer Analysis	439
11.3.3 Performing an Overlay Analysis	442
Chapter 12 Map Output	447
12.1 Lesson: Adding Dynamic Legends, Scale Bars and North Arrows.....	448
12.1.1 Adding a Dynamic Legend to a Layout	452
12.1.2 Adding a Dynamic Scale Bar to a Layout.....	455
12.1.3 Adding a Dynamic North Arrow to a Layout	458
12.1.4 Adding a Coordinate System Grid to a Layout.....	460
12.2 Lesson: Creating Map Books	462
12.2.1 Creating a Map Book.....	466
12.2.2 Navigating Through the Map Book	470
12.2.3 Publishing the Map Book.....	471

Sample Lesson

5.1 Lesson: Importing GIS Data

Introduction

Importing GIS file formats into Civil 3D opens the door to a tremendous amount of data. Much of this data is free and can be integrated into your mapping system. In this lesson, you begin by learning the formats and types of data that can be imported into Civil 3D, and guidelines around integrating other mapping data into your mapping system. You then import an ArcView SHP file into Civil 3D.

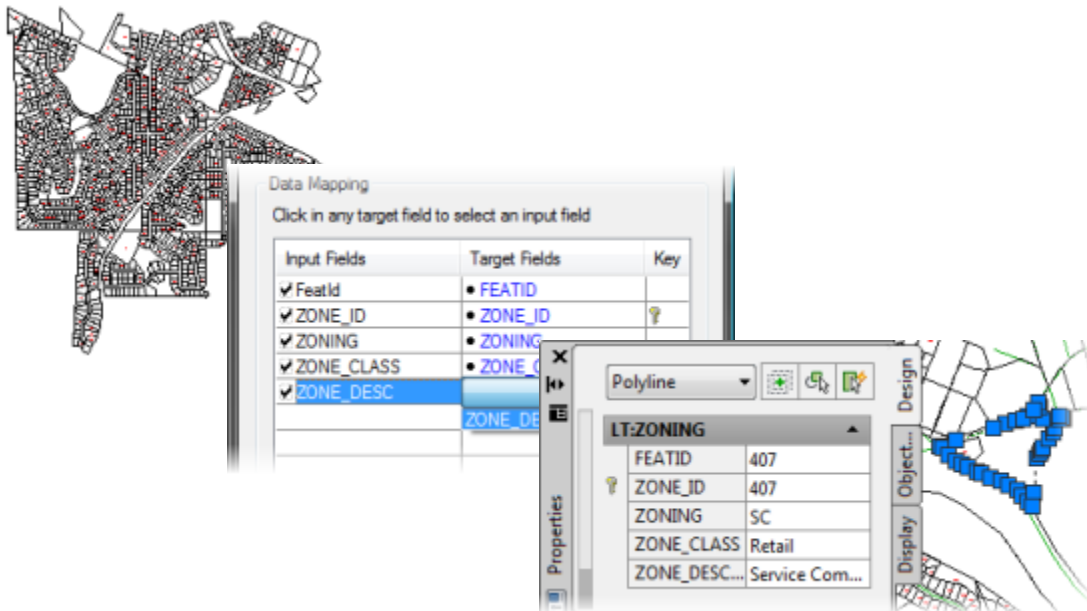

Key Concepts

Concepts and key terms covered in this lesson are:

- Import
 - Geometry
 - Attributes
 - Coordinate Systems
- Import dialog box

Objectives

After completing this lesson, you will be able to:

- Describe what Map Import is.
- List the components that can be imported, and how Civil 3D interprets incoming data.
- Identify and explain the tools used to import GIS data.
- Import street segments with Object Data.
- Import zoning polygons with an external data source.

About Importing GIS Data into Civil 3D

GIS Data generally contains three types of data: geometry, attributes, and the coordinate system it was created in. Using the map import tools, you can define how Civil 3D interprets and imports all three types of data.

The Map Import commands are used to convert other GIS formats into AutoCAD objects with attributes. These new AutoCAD objects are saved in the drawing file, with no link to the original GIS source.



Civil 3D can also connect to data as a feature source and work with these files in their native format. This functionality is covered in another lesson.

Geometry

All GIS formats are different. Civil 3D imports the data in such a way as to represent the native format as closely as possible. An example of this functionality is when importing line data from an ArcView shape file, any segments in the incoming file that have vertexes are imported as polylines, while those that are simple lines with a start and endpoint are imported as lines.

Points can be imported as either AutoCAD points, or blocks that are defined in the drawing.

Attributes

Attributes that are associated with incoming data can be mapped to Object Data, or can be imported to an attached data source, such as a Microsoft Access database table, and linked to the objects at the same time.

Coordinate Systems

If the incoming file has coordinate system information associated with it, either within the file itself, or a companion file, Civil 3D will read this information and convert the coordinates to the target drawing file. If there is no coordinate system information in the incoming file, you can assign a coordinate system to it during the import procedure.

Spatial Filters

Some GIS applications can manage larger data sets than can be reasonably managed within Civil 3D. Spatial filters enable you to limit the amount of data that you import based on a location in the current map.

Guidelines for Preparing for Map Import

You can start a new drawing and simply import data. In most cases, you want to prepare a target drawing with layers, Object Data tables, or attached data sources that will receive the incoming data. This is especially true if your office has mapping standards that must be adhered to, or if you are importing into an existing drawing that already has all the layers, Object Data tables, or attached data sources present.

Another important point when preparing for an import is to have some familiarity with the incoming data. This may come from metadata or documentation of some kind. The best way to qualify the incoming data is to use the native application to review. However, this is not always possible, in which case the import process might be a trial and error process until you can make the correct settings for the final import.



If you perform the same type of import regularly, you can save a profile of the settings and load the profile each time you perform an import. You can also create a drawing template that has all of the definitions such as Object Data tables, layers, blocks and so on.

The Import Interface

Once the target file is prepared, and the incoming data is qualified, the entire import procedure is performed in a single interface with various dialog boxes for the settings.

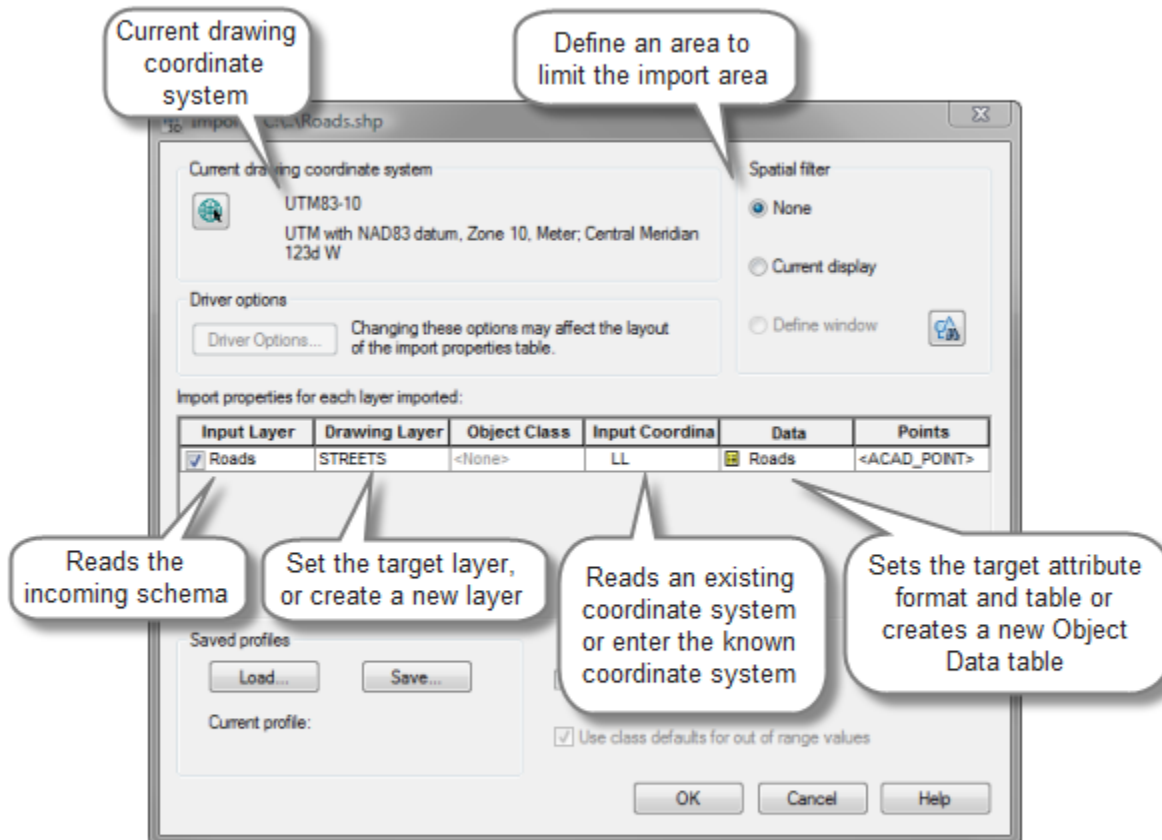

Exercises: Import Data from Other GIS Formats

In these exercises you will import street centerlines that were sent to you as an E00 file. An *ArcInfo* coverage may either be stored as a directory of related files, or exported into a single E00 export file from ArcInfo or ArcGIS, as in this exercise.

Then you will, import parcel polygons from an ArcView Shapefile and convert their coordinate system.

Finally, you will create centroids and move the attached data from each polyline to the corresponding centroid. This is the first step in the process of cleaning the geometry, an important process whenever base map data is imported.

The use of the import command is very similar for all the different types of supported GIS data file formats. However, there are some differences depending on the type of geometry that is contained in those files (points, lines, or polygons).

You do the following:

- Import streets from an E00 file.
- Import parcels from an ArcView shape file and convert its coordinate system.
- Create centroids for the parcel polygons.

5.1.1 Importing an ArcInfo Coverage



For these exercises you should be in the *Planning and Analysis* workspace

In this exercise you will import street centerlines that were sent to you as an E00 file. An *ArcInfo* coverage may either be stored as a directory of related files, or exported into a single E00 export file from ArcInfo or ArcGIS, as in this exercise.

1. Press **Ctrl + N** and select the template **map2d.dwt** from the folder *Map Book Templates*, to start a new, blank drawing.
2. Select **Ribbon: Insert ⇒ Import ⇒ Map Import**.

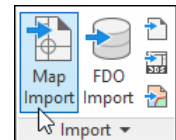

The *Import Location* dialog box opens.

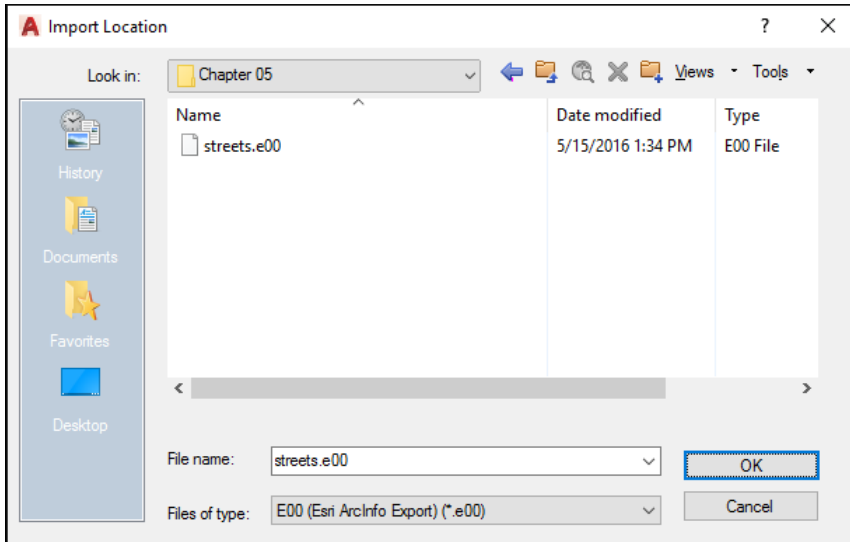

3. Set the file type to **ESRI ArcInfo Export (E00)**.
4. Browse to the **Chapter 05** folder, select **streets.e00**, and click **<<OK>>**.

In the *Import* dialog box you can configure the *Layer*, *Coordinate Conversion*, and *Data* options that you wish to use to import the information into *AutoCAD*.

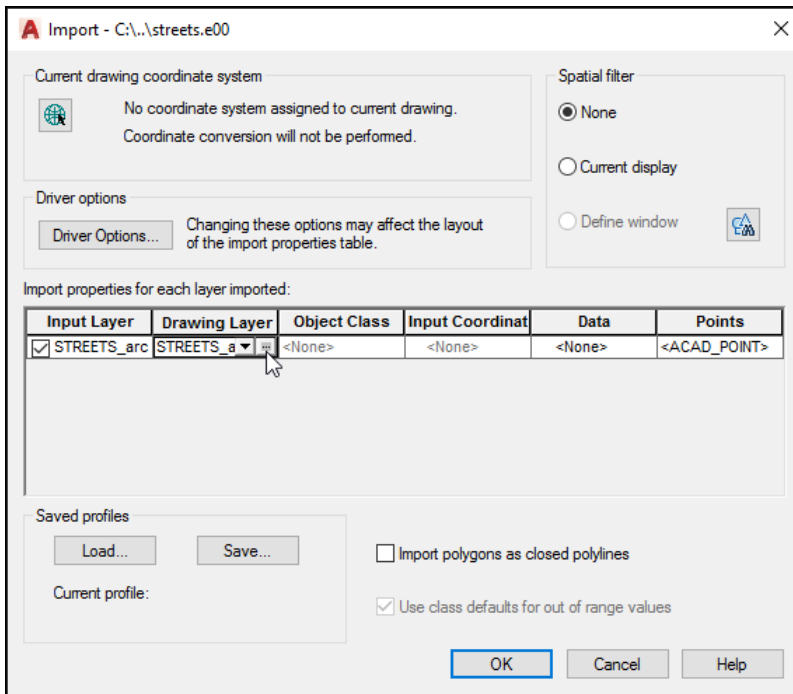

5. Ensure that the **STREETS_arc** Input Layer is selected.
6. Click on the **Drawing Layer** field in the **STREETS_arc** row, to activate the **More button <<...>>**.
7. Click the **More button <<...>>** to launch the *Layer Mapping* dialog box.

Here you can choose to import the drawing objects onto an existing layer, create a new layer, or select a column of data from the file that you are importing to determine the layer names. This last option will allow you to do some basic thematic mapping during the import of the objects. For example, if you were importing parcel data and that data set had a column for zoning. You could have the import command create a new layer for each zoning type and place each parcel on the appropriate layer for its zoning designation. (See *Additional Exercises* at the end of this chapter for more information).

In this exercise, you will place all of the streets on one new layer.

8. Choose the **Create on new layer** option to activate the text box.
9. Enter **"Streets"** for the layer name.
10. Click **<<OK>>** to return to the *Import* dialog box.

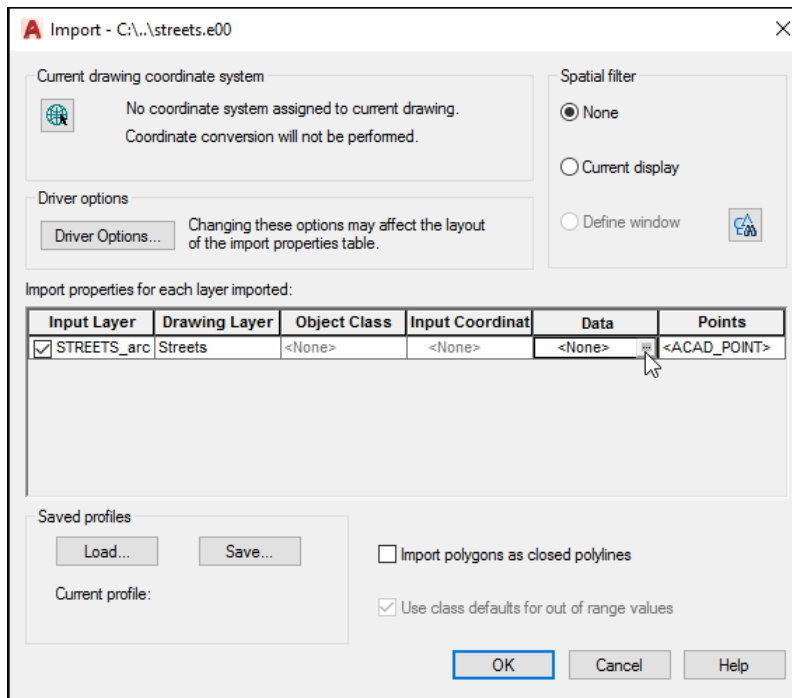
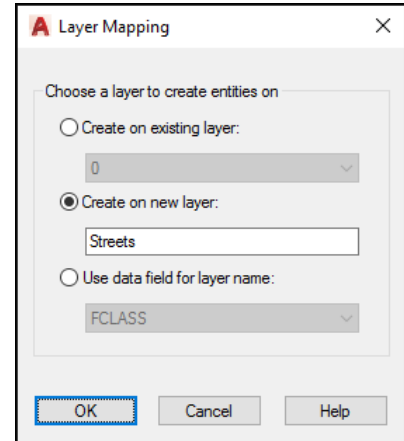

11. Click on the **Data** field in the **STREETS_arc** row to activate the **More button <<...>>**.
12. Click the **More button <<...>>** to launch the *Attribute Data* dialog box.

Here you specify what attribute data to import and where to store it. You can enter the desired name for the *Object Data Table* and select the desired fields to import. This is the step that allows you to bring the intelligence of the GIS file along with the geometry into *AutoCAD*. By creating the object data table and populating it with the information provided in the coverage you will be able to click on a street and find the street name, type, speed limit, and any other information that was added by the GIS department. This will also allow you to edit the geometry and data from the GIS file in *AutoCAD* and then export it back to any of the supported GIS formats without losing any of the attached data. If you leave the *Data* option set to *None* or *Do not import attribute data*, then you will only import the geometry of the file and you will lose all of the attached information.

13. Choose the **Create object data** option to activate the *Object Data* section.
14. Change the **Object Data** table name to **Streets**.
15. Click <<**Select Fields**>>.

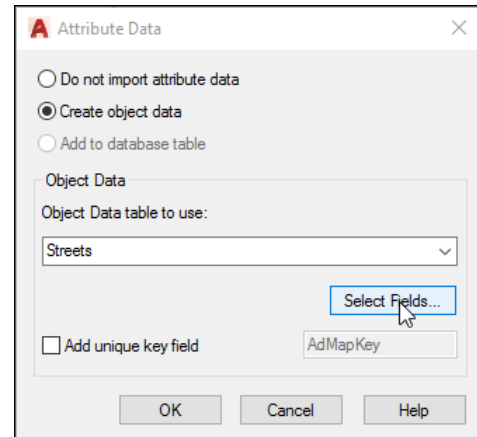

Here you specify which fields to import into the *Object Data* table.

16. Deselect all **Input Fields** except **NAME_FULL**, **TYPE**, **SPEED**, **OWNER**, **PAVED**, and **FCLASS**.

You only need to import the fields that you want to have available. So if there is extraneous data that you don't need, you can skip it and keep the file size smaller.

It is also important to understand that many GIS programs store geometric data, like length and area, in data tables, while in *AutoCAD* the geometry is a physical property of the object. In this example, if you were to import the length field, it would be a static value in the object data table and would not update if the length of the line is altered.

17. Click <<**OK**>> to dismiss the *Object Data Mapping* dialog box.
18. Click <<**OK**>> to dismiss the *Attribute Data* dialog box.
19. Click <<**OK**>> in the **Import** dialog box to import the file.

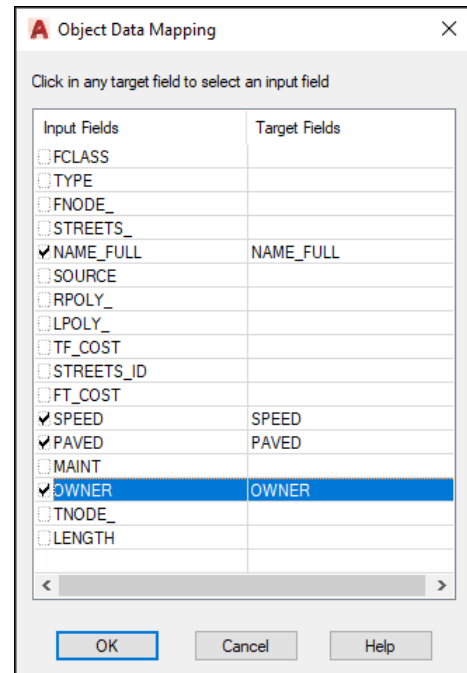

The streets are imported into the drawing as polylines, with the GIS data attached as *Object Data*.

20. Once the 287 objects are imported, zoom to Extents.



21. Select **Ribbon: Tools ⇒ Map Edit ⇒ Edit Object Data**.

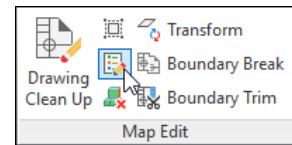

22. Pick a line segment anywhere in the drawing.

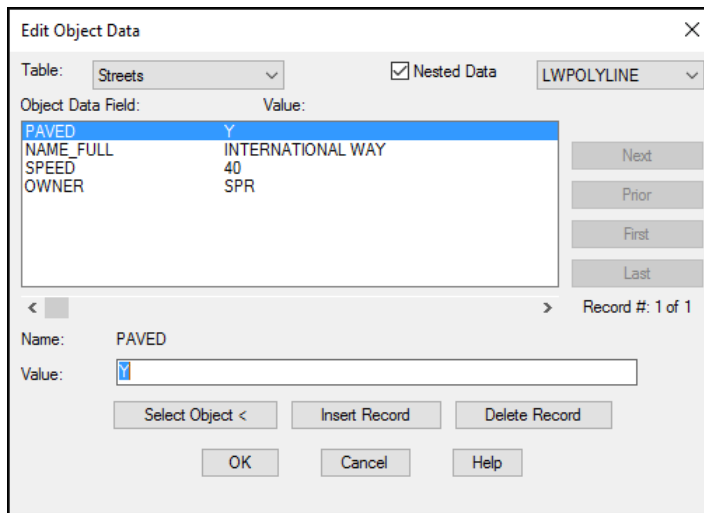

Here, you can view the object data associated with the line segment you picked. You can also change the value of any field in this object's data, or even add a record to a new or existing object. It is also possible to view and edit object data as an *AutoCAD* property.

23. View the object data associated with a few other line segments.

24. Click **<<Cancel>>** once you are through viewing the fields, to avoid saving any inadvertent changes.

25. **Save the** drawing as **Streets** in the **Chapter 05** folder.

5.1.2 Importing Polygons from an ArcView Shapefile

 For this exercise you should be in the *Planning and Analysis* workspace.

In this exercise you import parcel polygons from an ArcView Shapefile. This Shapefile geometry resides in a different coordinate system, and will be converted during the import process.

1. Open **City Taxlots OD.dwg** from the **Chapter 05** folder.

This drawing contains the city taxlots file that you worked with in previous chapters, with the *Tax/ot* attribute data as object data, attached to the centroids.

The county taxlots you are about to import are in a different coordinate system, which Civil 3D will convert during the import process. The first step is to assign the correct coordinate system to the base map.

2. Select **Ribbon: Map Setup ⇒ Coord System ⇒ Assign**.

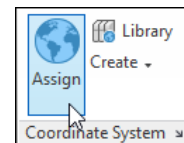

3. Click **<<Select Coordinate System>>** in the **Current Drawing** section, to open the *Coordinate System - Assign* dialog box.

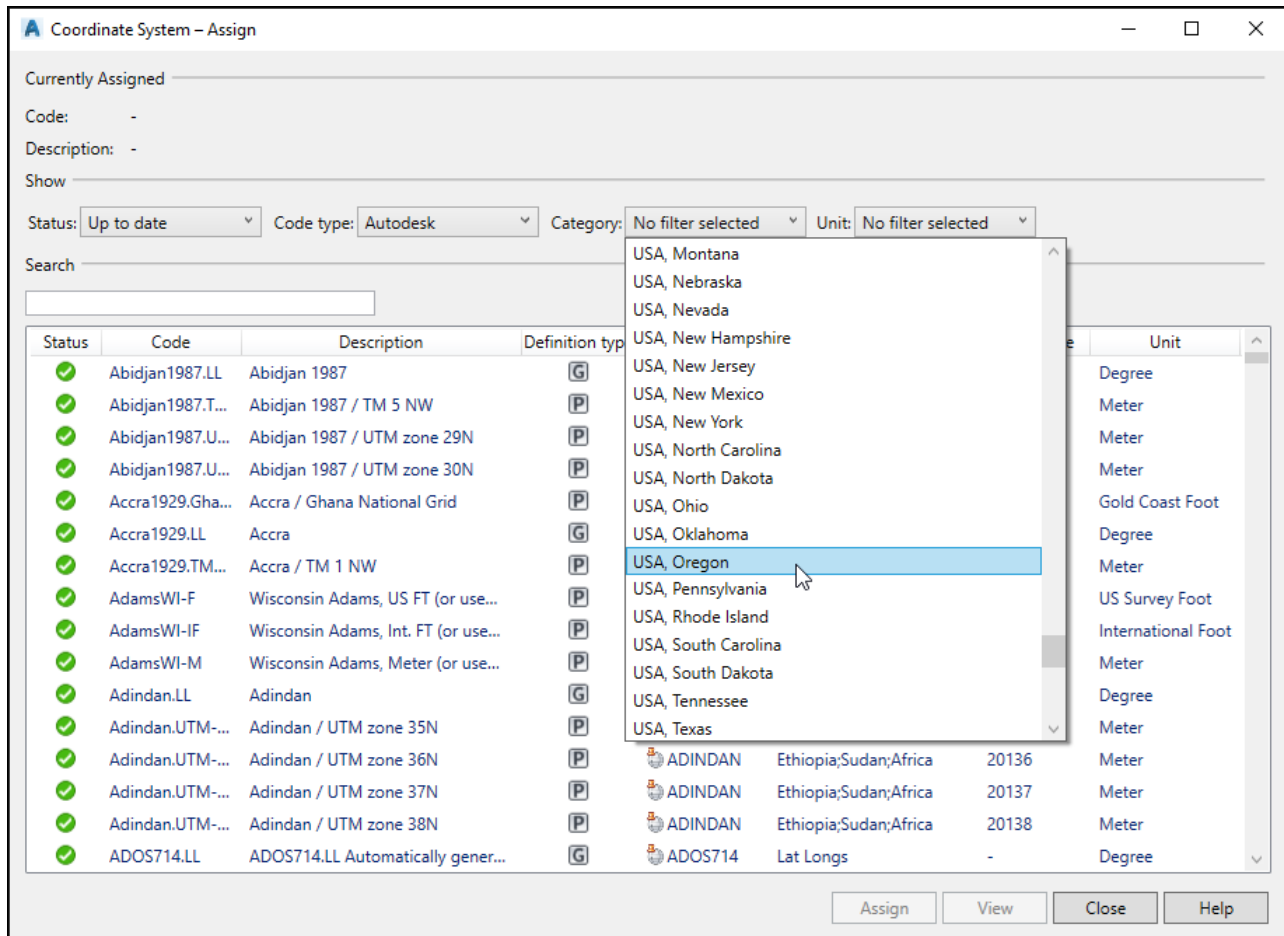

4. From the **Category** list, select **USA, Oregon**.
5. From the list, select **OR-S NAD27 Oregon State Planes (Polyconic), South Zone, US Foot**.

Notice the column of codes on the left, and that the code for the selected coordinate system is *OR-S*.



Once you become familiar with commonly used coordinate systems in your region, you can learn the short codes and simply enter them in the *Coordinate System - Assign* dialog box.

6. Click **<<Assign>>** to assign the **Global Coordinate System**.

The drawing is now identified with the *NAD 27 State Plane* coordinate system - no conversion has occurred; you have simply assigned that coordinate system to this drawing. The *Ribbon* now displays the *Geolocation* tab.

Next, you will import the county GIS data, which is in a different coordinate system, and *Civil 3D* will convert it to this coordinate system.

7. Select **Ribbon: Insert ⇒ Import ⇒ Map Import**.

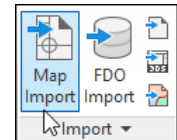

The *Import Location* dialog box opens.

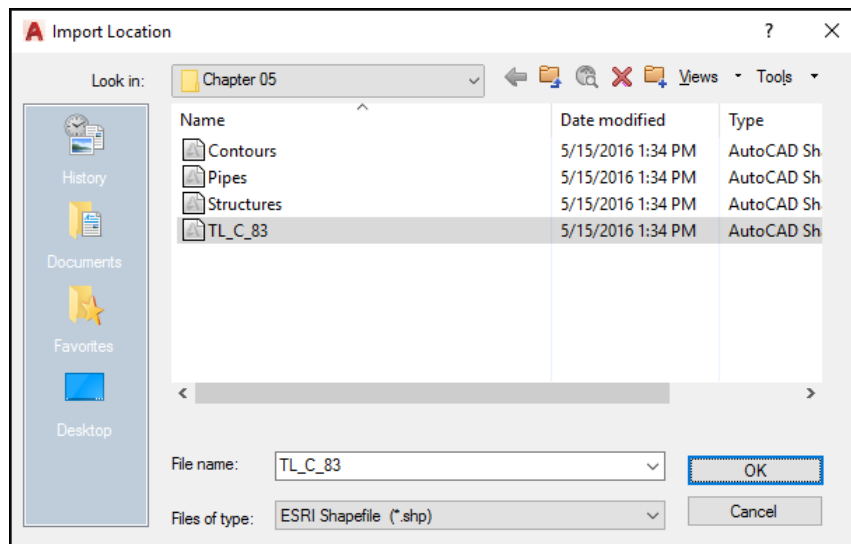

8. Set the file type to **ESRI Shapefile (*.shp)**.
9. Navigate to the **Chapter 05** folder and select **TL_C_83**.
10. Click **<<OK>>** to launch the *Import* dialog box.

Here you specify all import parameters.

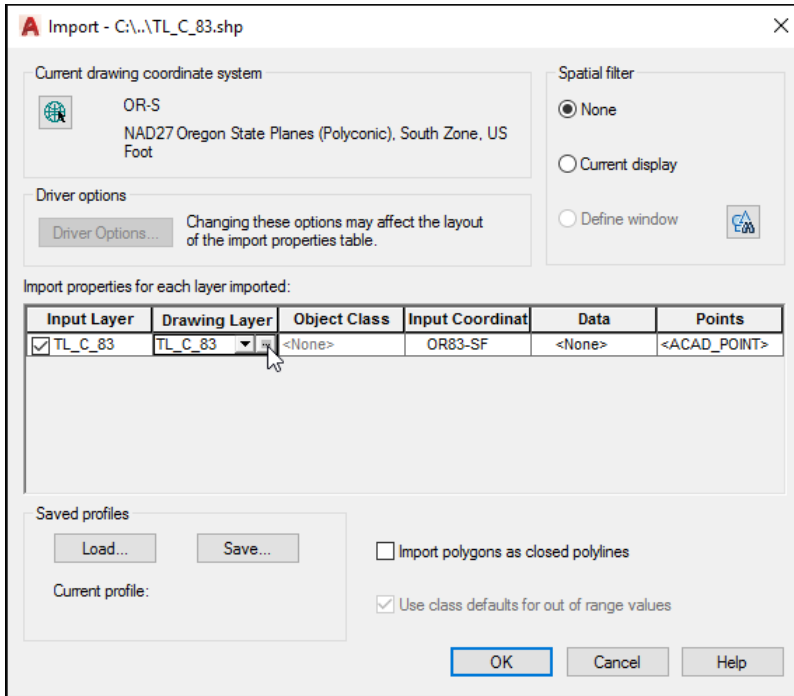

11. Click on the **Drawing Layer** field in the **TL_C_83** row to activate the **More button** <<...>>.

12. Click the **More button** <<...>> to open the *Layer Mapping* dialog box.

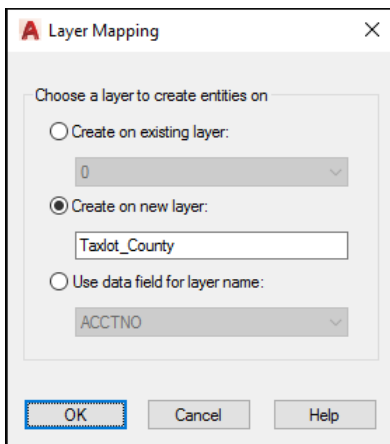

13. Choose the **Create on new layer** option to activate the text field.

14. Enter **Taxlot_County** for the new layer name.

15. Click <<**OK**>> to return to the *Import* dialog box.

Notice that the *Current drawing coordinate system* (the base map into which you are now importing this *Shapefile*) is in NAD27, which you set at the beginning of this exercise.

Also notice that the *Input Coordinate System* is showing OR83-SF, which is the code for *NAD83 Oregon State Planes (Polyconic), South Zone, US Foot*.

Civil 3D is getting this information from the PRJ file, that accompanies the .SHP file. This file contains the coordinate system information. When you acquire shapefiles from others, always ask for coordinate system information. If there is not an accompanying PRJ file, but the coordinate system is known, you could use the More button <<...>> in the *Input Coordinates* field to select it manually, using the *Coordinate System Library*.

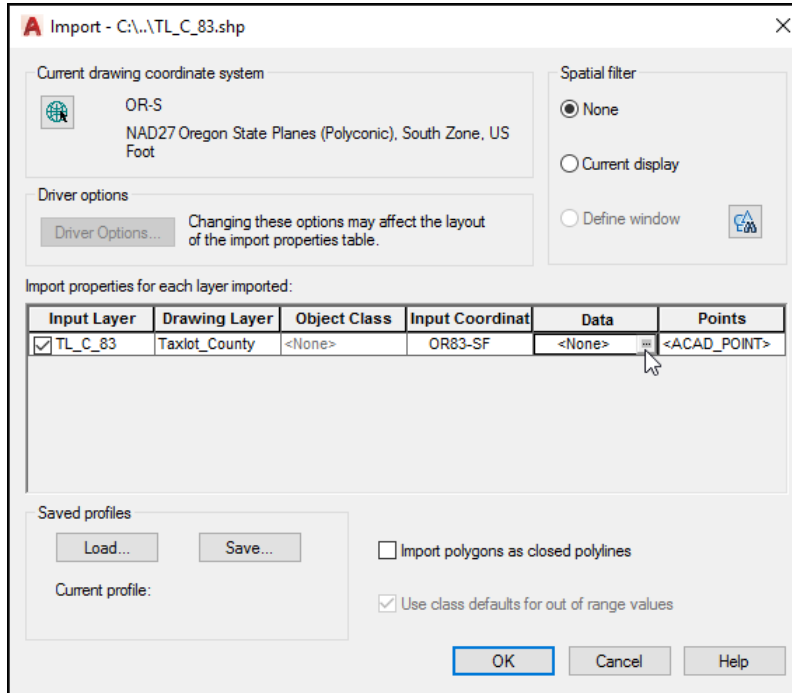

16. Click on the **Data** field to activate the **More button** <<...>>.
17. Click the **More button** <<...>> to open the *Attribute Data* dialog box.
18. Choose the **Create object data** option to activate the *External Database* section.
19. Select **Parcels** from the **Object data table** list.

The object data table exists in the City Taxlots OD drawing.

Civil 3D will add the new records to the existing object data table during the import process.

20. Click <<**OK**>> to return to the *Import* dialog box.

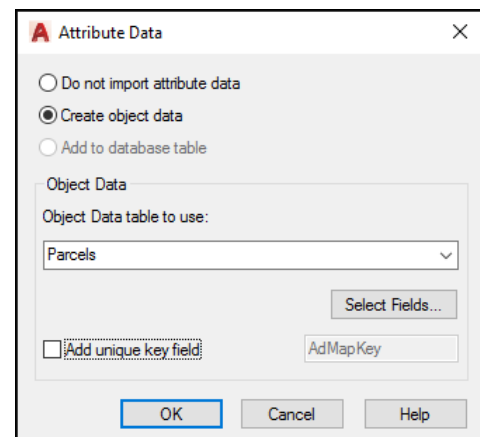

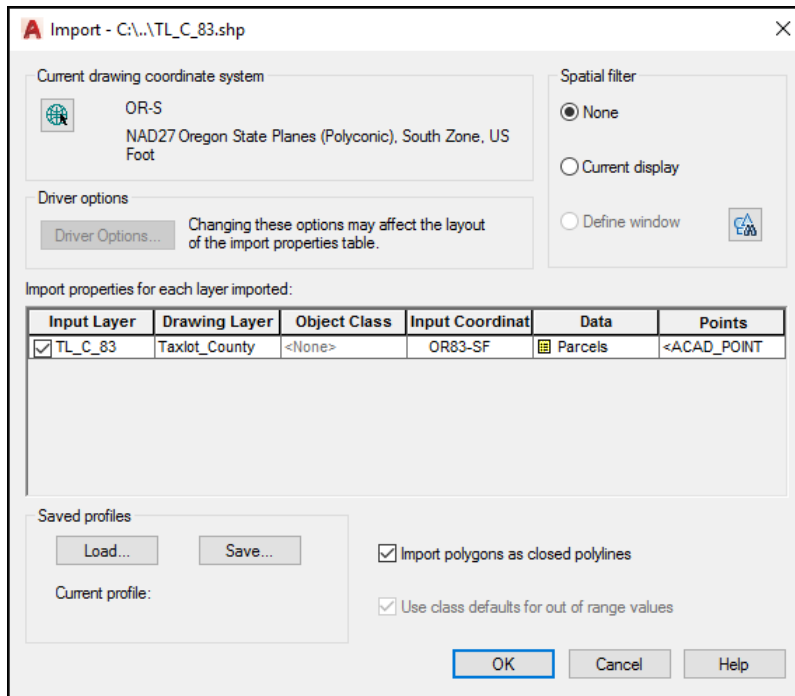

21. **Enable the Import polygons as closed polylines option.**

This will create each taxlot as a closed polyline, as opposed to a polygon object.

22. Click **<<OK>>** to import the file.

Civil 3D will process 396 objects and import them into the current drawing and will append 396 corresponding records to the attached database.

23. Zoom to Extents. Your drawing should look like this:

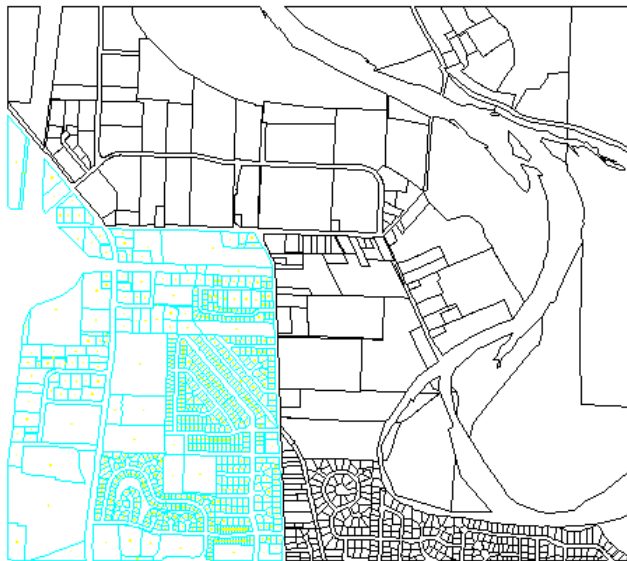

The county parcels have been imported and converted to the coordinate system of the city taxlots drawing.

24. Save the drawing as **Regional Taxlots.dwg** in the **Chapter 05 folder**.

5.1.3 Creating Centroids

 For this exercise you should be in the *Planning and Analysis* workspace.

In this exercise you will first create centroids and move the attached data from each polyline to the corresponding centroid. This is the first step in the process of cleaning the geometry, an important process whenever base map data is imported.

1. Continue working in the **Regional Taxlots.dwg** that you created in the last exercise.
2. **Freeze** the **Taxlots** and **Centroid** layers to isolate the *Taxlot County* layer.

3. Select **Ribbon: Create** ⇒ **Drawing Objects** ⇒ **Create Centroids**.

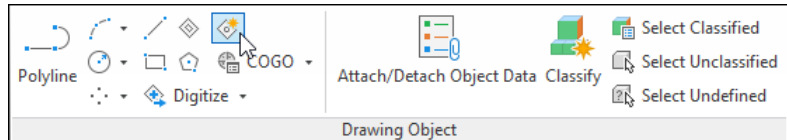

The *Create Centroids* dialog box opens.

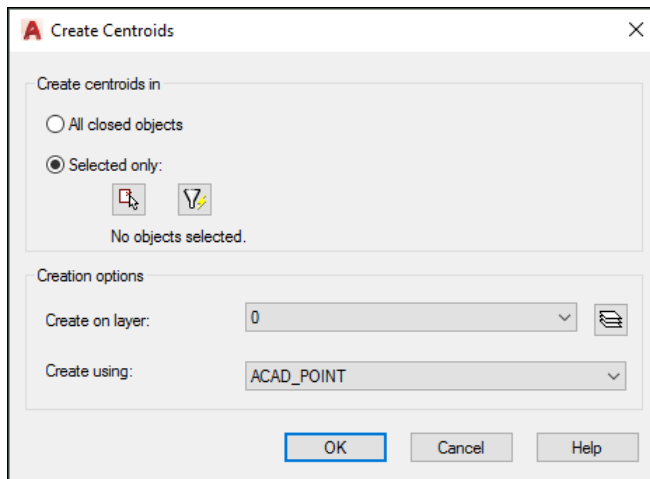



4. In the **Create Centroids in** section, choose **Selected only**:

5. Click the **select objects** button 

This temporarily closes the dialog box so you can pick the objects.

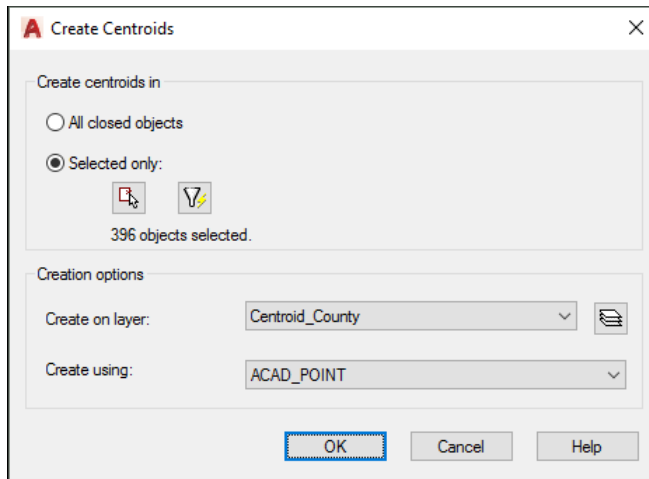
6. Pick all the polygons with a crossing window and press **Enter**.



7. Click the New Layer button  to make the layer **Centroid_County** on which to create the centroids.
8. Confirm that **ACAD_POINT** is selected in the **Create using** field.
9. Click **<<OK>>** to create a centroid for each closed polygon.

This creates a point at the geometric center of each polygon and moves the data from the polyline to the new centroid.

10. Pick one of the new centroids, then right-click and select **⇒ Properties**.
11. In the *Properties* palette, scroll to the bottom and notice the attribute data from the SHP file is now attached to the tax lot centroids.

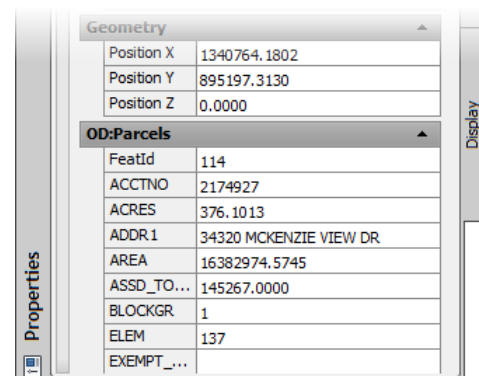

12. Save the Drawing.

Lesson Review

In these exercises you imported street centerlines that were sent to you as an E00 file. An *ArcInfo* coverage may either be stored as a directory of related files, or exported into a single E00 export file from ArcInfo or ArcGIS, as in this exercise.

Then you imported parcel polygons from an ArcView Shapefile and converted their coordinate system.

Finally, you created centroids and moved the attached data from each polyline to the corresponding centroid. This is the first step in the process of cleaning the geometry, an important process whenever base map data is imported.

7.3 Lesson: Connecting to Raster and Raster Surfaces

Introduction

Connecting to raster data as a feature source is similar to inserting images using *Image Insert*. In each case, the file is only referenced and not part of the drawing itself. In this lesson, you also learn the differences between these two methods and the advantages of using the feature source connection. You also learn about the tools that are used to connect to a raster image, and then connect to a raster image.

Connecting to raster surfaces is similar to connecting to raster images. The main difference is that raster surfaces contain elevation data associated with each pixel. Civil 3D uses this method for simple surface analysis and visualization as part of the feature source. In this lesson, you learn the basic concepts of raster surfaces, the types of files that you can access, and how raster surfaces can be used as part of your mapping system. You then connect to a digital elevation model, and add it to your map.

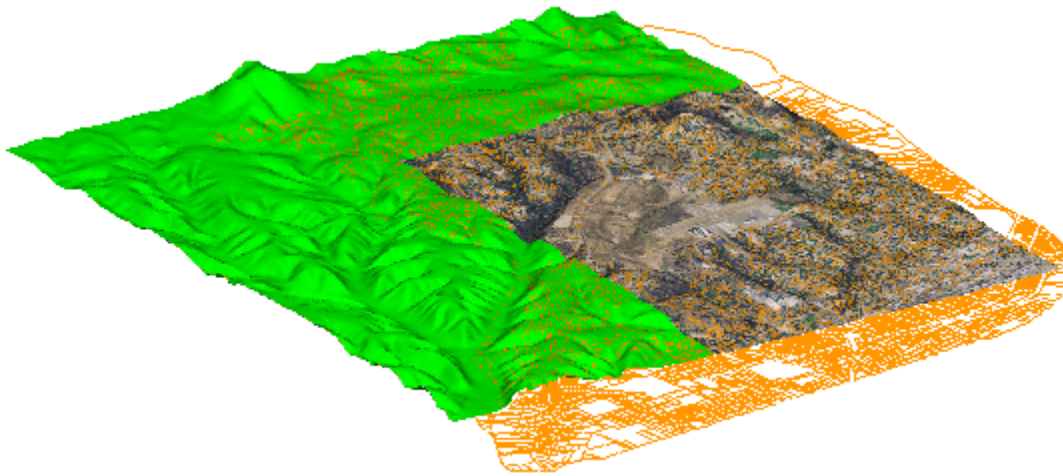

Key Concepts

Concepts and key terms covered in this lesson are:

- Raster feature sources
- Raster surfaces
- Viewing raster surfaces in 3D
- Draping raster and vectors over surfaces

Objectives

After completing this lesson, you will be able to:

- Describe what a raster feature source is.
- List the types of raster formats that can be accessed.
- Explain how raster surfaces can be used.
- Connect to an ortho photo.
- Connect to a raster surface.
- Drape vectors and raster over a raster surface.

Raster Feature Source Concepts

You can use raster data in Civil 3D through the Map Image Insert command and by connecting to raster as a feature source. There are some very powerful reasons to use a feature source connection rather than inserting raster:

- Performance
- File formats
- Coordinate conversion

Performance

The performance of raster as a feature source is much better than that of raster inserted in a drawing. In some cases this performance enables access to raster that otherwise cannot be used because of file size.

File Formats

Connecting to raster as a feature source opens a larger selection of geospatial-based file formats to work with. In addition to the formats that are offered directly in standard Civil 3D, the fact that the feature data objects (FDO) technology is open source enables developers to write additional FDO providers to access even more file formats.

The following illustration shows the file formats available in the Map Image Insert command. While it offers a wide variety of file formats to select from, when considering the geospatial specific formats, it is fairly limited.

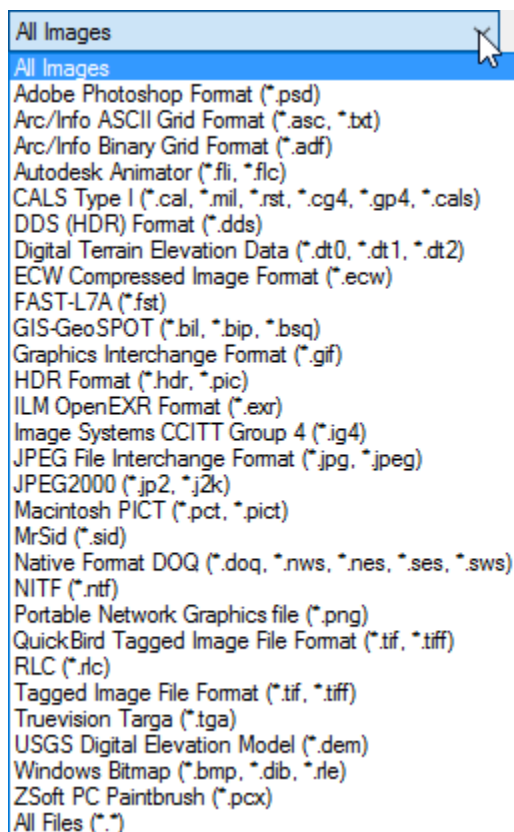

The following illustration shows the file formats available when connecting to raster as a feature source. The formats available through this method are especially useful for geospatial applications.

Raster Type	Formats
Raster-based surfaces	DEM (Digital Elevation Model), ESRI Grid, or Digital Terrain Elevation Data (DTED)
2D raster	JPEG and JPEG2K (Joint Photographic Experts Group), PNG (Portable Network Graphic), MrSID (Multi-Resolution Seamless Image Database), TIFF (Tagged Image File Format), ECW (Enhanced Compressed Wavelet)
WMS raster	Maps on a server
Other raster formats	BMP, CALS-I, ECW, FLIC, GeoSPOT, IG4, IGS, IKONOS, JFIF, LANDSAT FAST, L7A, NITF, PCX, PICT, Quickbird TIFF, RLC 1 and 2 , TARGA

Coordinate Conversion

Connecting to raster as a feature source enables the coordinates of the raster to be converted to the coordinates of the current drawing. This is a very important distinction between connecting and inserting raster. When using Map raster insert, whatever the coordinates of the raster are determines the coordinates of your map. This is very limiting when compared to the coordinate conversion available using a raster feature source connection.

Raster Surface Concepts

When working with raster as feature sources, the process and procedures to connect and add both standard raster and raster surfaces are the same.

Both types of raster are composed of pixels. In the case of raster surfaces, each pixel has a Z value rather than a value such as grey scale or color that produces a “picture”. Civil 3D can interpret the Z values in a raster surface, and produce three dimensional views and analysis.

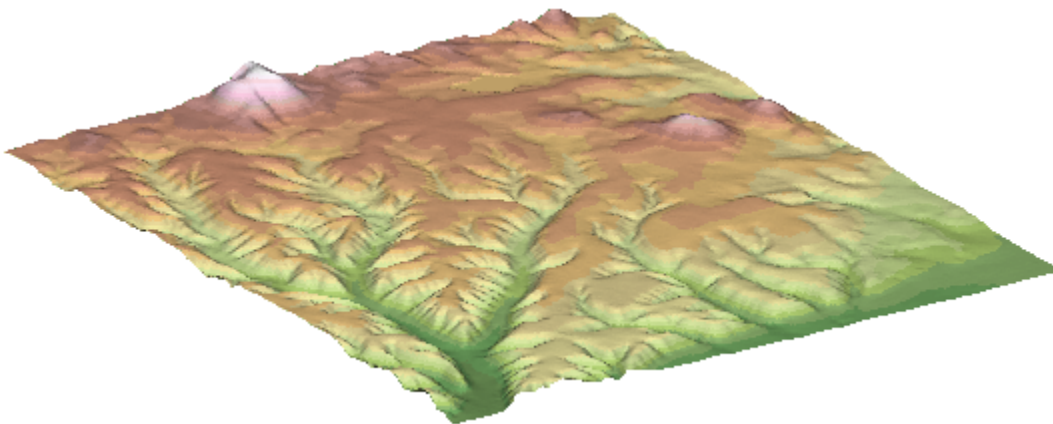

Raster Feature Layers

When a raster is connected to, and added to a map, the management of the feature layer is the same as that of vector based feature layers.

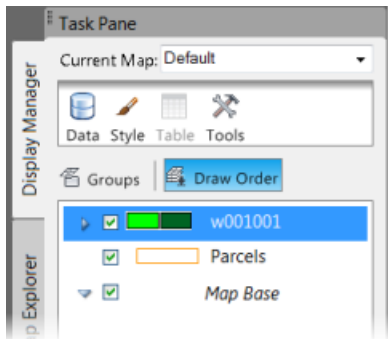

Working with Raster Surfaces

There are several tools available to take advantage of the elevation data that is inherent in a raster surface. These tools include creating contours, slope, aspect, and elevation analysis, draping, and assigning exaggeration values to the elevations. In this lesson, you work with draping and exaggeration.

Draping

Draping refers to vector and raster objects which adopt the three dimensional characteristics of the underlying surface. By default, when a raster surface feature layer is present in a drawing, all other feature layers, both vector and raster drape over the raster surface depending on the draw order of the feature layers.



AutoCAD objects do not drape over raster surfaces.

Exaggeration

Exaggeration can be applied to raster surfaces to create a more impactful representation of the terrain when needed.

In the following illustrations, the image on the left is a raster viewed in 3D with no exaggeration. The image on the right is the same raster surface with an exaggeration value of 3x.

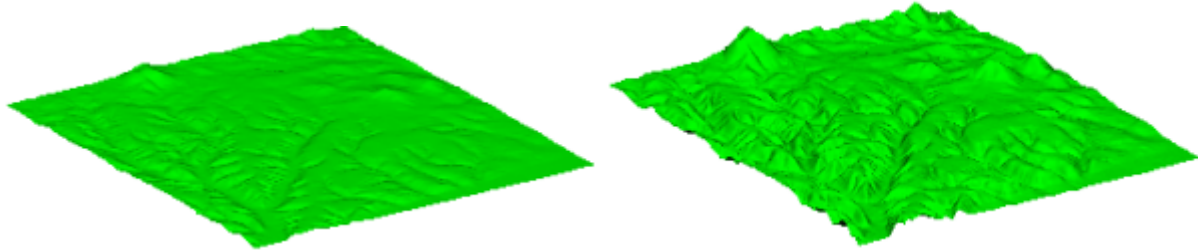

Exaggeration should be used sparingly. It often dramatically misrepresents the map.

Exercises: Connecting to Raster and Raster Surfaces

In these exercises, you start in a drawing that has a parcel feature layer connected. You connect to a raster image of an ortho photo of the area of interest. You then connect to a raster surface, change the draw order, and view the map in 3D.

You do the following:

- Connect to a raster image and add it to the map.
- Change the draw order to view the parcels on top of the raster.
- Connect to and add a raster surface to the map.
- Set the draw order to drape the parcels and ortho photo over the surface.

7.3.1 Connecting to an Aerial Photo

 For this exercise you should be in the *Planning and Analysis* workspace.

1. Open the drawing **Connect to Raster.dwg** from the **Chapter 07** folder.

In the first series of steps, you connect to the raster image and add it to the map.

2. If the **Task Pane** is not visible, at the command line enter:
Command: MAPSPACE.
3. At the command line, enter **ON** to display the *Task Pane*, which includes the *Display Manager*.
4. In the **Display Manager**, confirm that the **Groups** button is selected.
5. In the **Display Manager**, click the **Data** button, and then select ⇒ **Connect to Data...** .

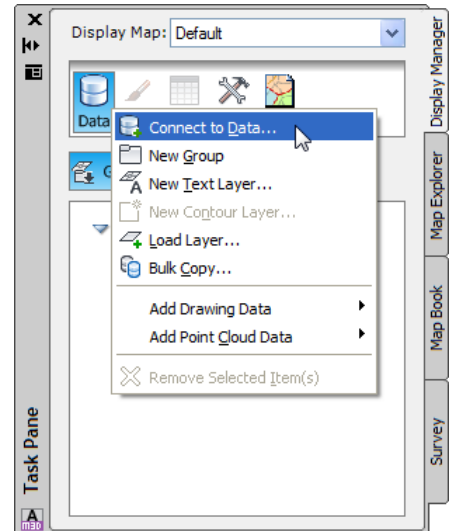

The *Data Connect* palette opens. Here you can select from many different data providers or sources. In this exercise you will be connecting to a raster image file.

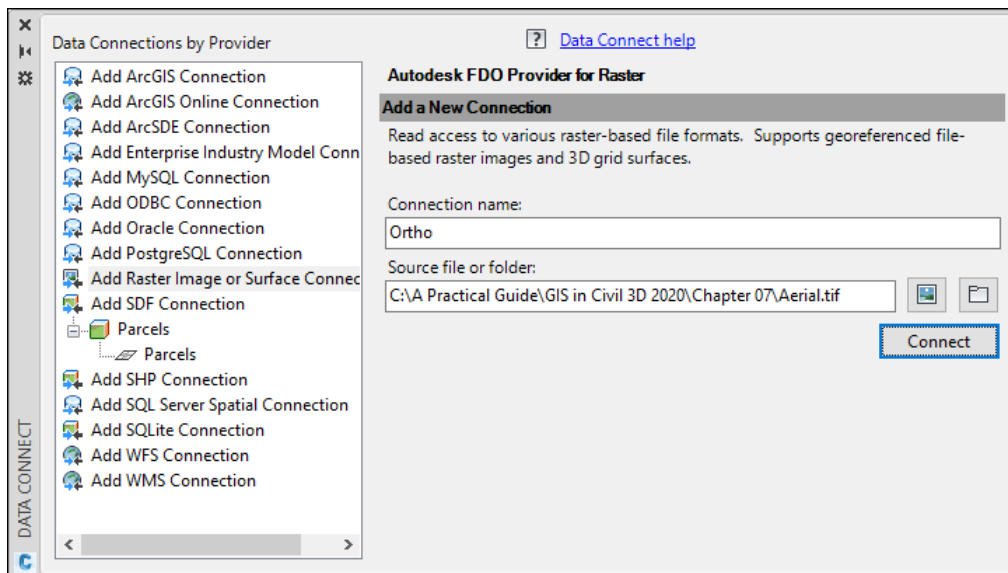

6. From the *Data Connections by Provider* list, select **Add Raster Image or Surface Connection**.
7. Change the *Connection name:* to **Ortho**.
8. Click the file button  and browse to: **C:\A Practical Guide\GIS in Civil 3D 2020\Chapter 07**, and select **Aerial.tif**.
9. Click **<<Connect>>**.

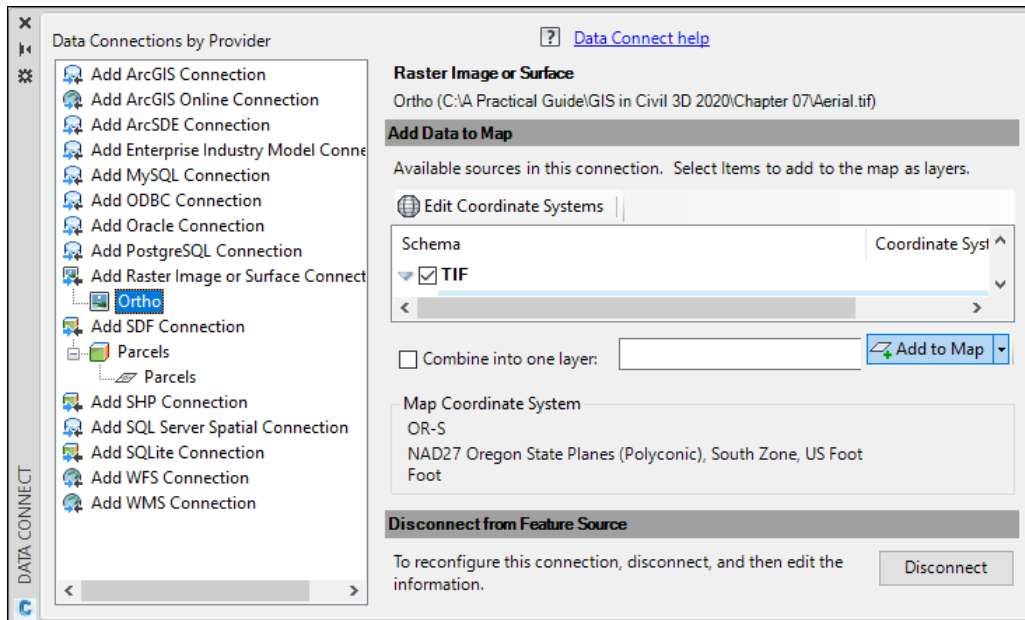

10. Click <<Add to Map>>.
11. Close the *Data Connect* palette.

Notice the *feature layer Aerial* now appears in the *Display Manager*. A layer in the *Display Manager* is different than an *AutoCAD* layer; it is the name of a data source and where you manage its properties.

Notice the aerial photo is on top of the parcels.

12. In the **Display Manager**, select the **Draw Order** button.

The list of feature layers is displayed in the current draw order. The order these are listed in matches the feature layers in the drawing.

13. Drag the *Parcels* feature layer above the *Aerial* layer.

The first time you change the sequence of the *Display Map Draw Order* list in a drawing, an alert is displayed, informing you that the *Draw Order* list will now control the visual display of feature layers.

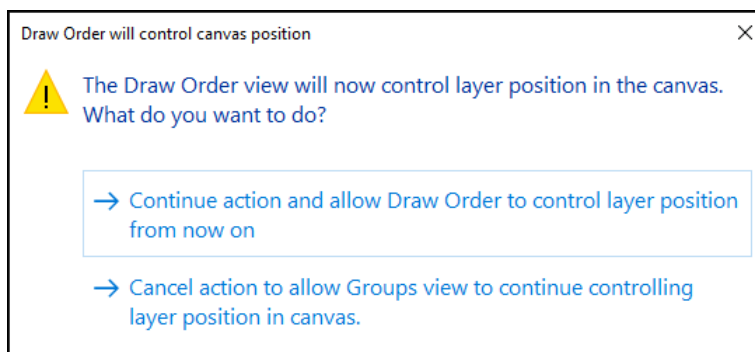

14. Click **Continue action and allow Draw Order to control layer position from now on**.
15. Zoom into the map to view the image with the parcels overlaid.

16. Save the drawing for use in the next exercise.

7.3.2 Connecting to a Raster Surface

In this exercise you connect to and add to the map an elevation enabled raster, or raster surface. Once the surface raster is added to the map, you change the draw order, and view the map in 3D. Any feature layer that is on top of the surface will automatically drapes over the surface.

1. Continue working in **Connect to Raster.dwg** from the previous exercise.

If you did not complete the previous exercise you can open the drawing **Connect to Surface.dwg**.

2. Connect to a Raster Surface. Repeat Steps 5-11 from the previous exercise using the following information:

- For the Connection Name enter **Elevation**
- Connect to the file **Existing Ground.dem** in the **Chapter 07** folder

3. In the **Display Manager**, select **Draw Order**.

The list of feature layers is displayed in the current draw order. The order these are listed in matches the feature layers in the drawing.

4. Drag the feature layers to match the following order:

- Parcels
- Aerial
- Existing Ground

To view the Parcels and Aerial features draped over the Existing Ground DEM feature, you need to switch the drawing editor from 2D to 3D views. The tools to switch views reside on the *Map Status Bar*. In the standard, out-of-the-box installation of Civil 3D, this status bar is not displayed by default. The display of the *Map Status Bar* is controlled by a system variable.

5. Enter **MAPSTATUSBAR** on the *Command Line*, and select **<Show>**.

The *Drawing Status Bar* now shows additional tools for some *AutoCAD Map 3D* functions, such as 2D / 3D Viewing, Vertical Exaggeration, Coordinate Systems and View Scale.

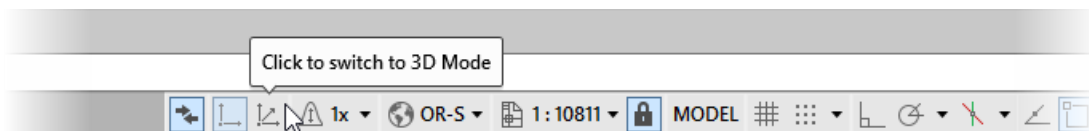

6. In the *Drawing Status Bar*, click the **3D** icon.

The drawing is displayed in 3D.

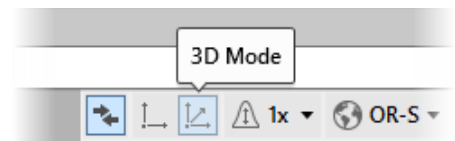

7. In the Status bar, for *Vertical Exaggeration*, select **2x**.

Note: It might take a few moments to optimize the layer.

8. Zoom into the drawing to view how the raster and parcels are draped over the surface raster.
9. Experiment with various Vertical Exaggeration values and 3D viewing angles.
10. In the **Display Manager**, turn the **Aerial** image off, and notice how the vector data in the *Parcels* layer are draped over the surface.

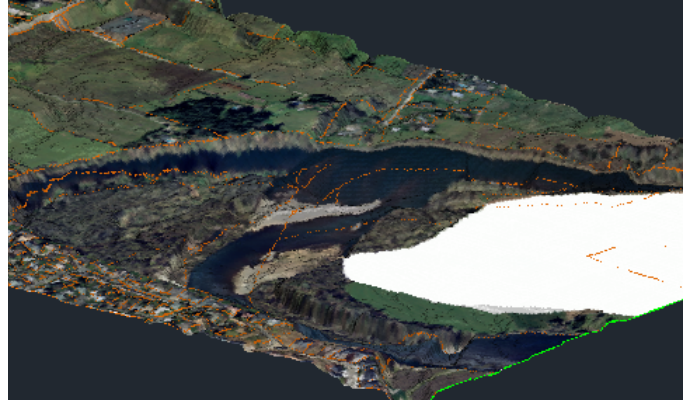

NOTE: Be careful when applying Vertical Exaggeration, and use it sparingly. While it can help visualize terrain in relatively flat areas, it can dramatically misrepresent actual conditions.

Lesson Review

In these exercises you integrated three different sources of data. Vector based parcels, an ortho photo, and a surface. Together, these sources of data were combined to view how the parcels and the image drape over the existing ground terrain.

Index

3D Modeling Workspace	8	Data Source Name	236
3D Navigation	284	Data Table	228
Add Data to a Map	214, 221	Data Table Tools	229
Adding New Features	318	Data View	89
Altering Properties	392	Datums	15
Anchors	36	Define Object Data	59
Angle Data	25	Digital Elevation Model	259, 283
Annotation Blocks	116	Display Manager	6
Annotation Template	116	Drafting & Annotation Workspace	8
ArcGIS Online	221	Drafting Settings	9
Attach Object Data	59, 66, 69	Draping	262, 286
Attribute Data	52, 53	Draw Order	230, 252
AutoCAD Attach	247	Drawing Cleanup	417
AutoCAD Options	9	Drawing Locks	359
AutoCommit	90	Drive Aliases	356
Autodesk Connector for ArcGIS	221	Duplicate Objects	35
Automatic Check In	316	Dynamic Annotation	114
Automatic Checkout	316	Edit Feature Attributes	315
AutoSave	9	Edit Feature Geometry	315
Best Route	435	Edit Object Data	59, 75, 76, 78
Bitonal	245	Editing Attributes	317
Block Attributes	55	Editing Existing Features	318
Bulk Copy	344	Editing Object Data Tables	79
Cancelling Checkout	317	Editing Transaction Model	399
Capture Area	257	Error Markers	427
Centroid	424	Esri account	221
Check-In/Checkout	316	Export file types	178
Civil 3D Workspace	8	Export Process	180
Classifying Existing Objects	151	Exporting	177
Clustered Nodes	35, 418	Exporting Civil 3D Objects	202
COGO Inquiry	24	Expression Builder	309, 310
Command Line	9	External Data Sources	53
Compound Queries	370	External Databases	84
Connecting to ODBC	234	Feature Class	212
Connecting to Raster	263	Feature Filters	308
Constraints	336	Feature Joins	325
Contextual Ribbons	5	Feature Layer	213, 227
Contours	287	Feature Layer Selectivity	230
Convert Coordinate Systems	409	Feature Queries	308
Coordinate Conversion	261	Feature Source	206, 209
Coordinate Geometry	24	Feature Source Connect	210, 220, 248
Coordinate System	17, 163, 212, 236, 407	Feature Styles	270
Coordinate System Grid	460	Feature Thematic Maps	299
Coordinate Tracker	18	Filter to Select	311
Correlation Files	246	Flood Trace	435
Create scale ranges	295	Generating Links	86, 98, 99, 101
Creating New Classified Objects	156	GIS Contours	188
Creating New Features	317	Global Coordinate Systems	15
Crossing Objects	35, 418	Grey Scale	246
Current Drawings	355	Hillshading	285
Data Panel	403	Image Behavior	252
Data Queries	384	Image Correlation	248
Data Source	85	Image Frames	252

Image Insert	248	Raster Feature Layers	262
Import Attributes	163	Raster Feature Source	260
Import Coordinate Systems	163	Raster Metadata	247
Import Geometry	163	Raster Surface	246, 261
Import Interface	164	Raster Surface Styles	284
Import Spatial Filters	163	Raster Surface Themes	286
Inserting Dynamic Annotation	121	Raster Surfaces	259
Joins	324	reference grid	451
Layout Elements	449	Reference Management	252
Legend	449	Reference System	451
Line Feature Styles	274	Refresh Annotation	117
Link Template	85, 98, 99, 100	Relational Data Base Management Systems	209
Linking External Databases	85	Ribbon	4, 228
Links	415, 424	Save-Back	398
Location Queries	365, 368	Save-Back Options	401
Manually Link	101	Saved Queries	371
Map Book Dialog	465	Scale Bar	450
Map Book Template	463	Scale Dependent Styles	291
Map Books	447, 448	Scale Ranges	272
Map Explorer	6, 338	Schema	345
Map Status Bar	266	Schema Editor	338
Network Analysis	434	Shortest Path	434
Network Topologies	414	Source Drawings	354
Nodes	415, 424	SQL Queries	385
North Arrow	450	Style Editor	270
Object Class Objects	157	Style Editor Palette	272
Object Classes	152	Style Scale Ranges	270
Object Classification	138, 139, 156	Styles	272
Object Classification Definition File	140	Stylize Raster Surfaces	283
Object Data	54, 57, 67, 163, 385	Stylizing features	270
Objects	207	Surface	188
ODBC	234	Surface Exaggeration	263, 284
Online Map	256	Task Pane	5, 229, 358
Open Data Base Connectivity	235	Theme Feature Labels	301
Pipe Network	188	Theme Legend Labels	301
Planning & Analysis Workspace	8	Theme Ramps	301
Point Feature Styles	273	Themes	298, 393
Polygon Feature Styles	274	Tolerance	36
Polygon Overlay	436	Topology Analysis	433
Polygon Topologies	423	Topology Object Data	416
Projection	15	UDL file	85
Properties Palette	76	Update Annotation	117
Property Alteration	394	User Interface	1
Property Queries	365, 369	Validating Standards	150, 336, 339, 393
Pseudo Nodes	35	Vector Objects	245
Quick View	357	Viewing Linked Data	102
Ranges and Styles	293	Workspaces	8
Raster	244, 245, 259		