



# **A Practical Guide to AutoCAD® 2020**

**Tracy Chadwick and Rick Ellis**

*Foreword written by Lynn Allen*



A CADapult Press Publication

---

## Copyright

Copyright © CADapult Press, Inc. 2019

All rights reserved. No part of this publication may be reproduced in any form, or by any means electronic, mechanical, recording, photocopying, or otherwise, without written permission from the publisher, except for brief quotations used in reviews, or for marketing purposes specific to the promotion of this work.

ISBN: 978-1-934865-43-9

Although CADapult Press has made every attempt to ensure the accuracy of the contents of this book, the publisher and author make no representations or warranty with respect to accuracy or completeness of the contents in this book, including without limitation warranties of fitness for a particular purpose. The datasets included in this book are for training purposes only.

Autodesk screen shots reprinted with the permission of Autodesk, Inc.

Autodesk, AutoCAD, DWG, and the DWG logo are registered trademarks or trademarks of Autodesk, Inc., and/or its subsidiaries and/or affiliates in the USA and other countries. All other trademarks are the property of their respective owners.

Published in the United States of America by:

CADapult Press

(503) 829-8929

books@cadapult-software.com

Printed and manufactured in the United States of America

## About the Authors

**Tracy Chadwick** serves as coordinator and instructor for the Computer Drafting Technology program at Hutchinson Community College in Hutchinson, Kansas. He is responsible for teaching a wide range of courses, including those on engineering graphics, AutoCAD software, Inventor software, and Revit Architecture software.

Tracy has been an AutoCAD user since 1995, and has been teaching AutoCAD classes to working professionals and college students since 2001. His experience and dedication to teaching led to him being recognized by Autodesk, Inc. with the North America Award for Distinguished Performance in AutoCAD Software Training.

Tracy has also been recognized as a top rated speaker at Autodesk University, where he has presented for several years. He has recently begun serving as a mentor to first-time Autodesk University speakers.

Tracy can be reached at: [tracy@cadapult-software.com](mailto:tracy@cadapult-software.com)

**Rick Ellis** has worked with and taught AutoCAD Map 3D since the mid-90s, along with Civil 3D and other Autodesk products. He is the Author of several critically acclaimed books on AutoCAD Map 3D, Civil 3D and Land Desktop.

Rick continues to use AutoCAD Map 3D on projects in a production environment, in addition to teaching classes to organizations both large and small.

This practical background and approach has made him an award winning speaker at Autodesk University and a sought after instructor by organizations around the world.

Rick can be reached at: [rick@cadapult-software.com](mailto:rick@cadapult-software.com)

## Acknowledgements

Thank you to my wonderful wife Candace, and my two amazing daughters Sydney and Casey. Without their support I could never have completed this book. Thank you to all the students of the Computer Drafting Technology program at Hutchinson Community College. I am honored to have played a part in helping so many students achieve fulfilling careers over the last two decades. Thank you to Vince Puyear, who first introduced me to AutoCAD back in 1995. He started as my instructor, then later became my colleague, mentor, and friend. Thank you to Amber Brawner for lending her graphic design talent to this book, and for being a great friend. Last, but not least, thank you to Rick Ellis and CADapult Press for helping me to achieve my dream of being an author, so that I may spread my love for AutoCAD from beyond central Kansas to the world!

-Tracy Chadwick

# **A Practical Guide to AutoCAD® 2020**

## **Introduction**

Congratulations on choosing this course to help you learn how to use AutoCAD 2020. The term “practical” is used in the title because this course focuses on what you need to effectively use AutoCAD 2020, and does not complicate your learning experience with unnecessary details of every feature in the product. Should you want to pursue aspects of features and functionality in greater detail than provided in this course, you are directed and guided to that information.

Each lesson contains the concepts and principles of each feature to provide you with the background and foundation of knowledge that you need to complete the lesson. You then work through exercises to reinforce your understanding and provide you with practice on common tasks that other professionals are performing with AutoCAD 2020 in the workplace every day.

When you complete this course, you will be armed with the background and knowledge to apply AutoCAD to your job tasks, and become more effective and productive in your job.

## **Course Objectives**

The objectives of this course are performance based. In other words, once you have completed the course, you will be able to perform each objective listed. If you are already familiar with AutoCAD, you will be able to analyze your existing workflows, and make changes to improve your performance based on the tools and features that you learn and practice in this course.

After completing this course, you will be able to:

- Understand the user interface
- Navigate through drawings with pan and zoom commands
- Create drawing objects, including lines, arcs, and circles
- Create and modify polylines, including rectangles and polygons
- Use Layers to differentiate drawing objects
- Draw using Polar Tracking and coordinate methods
- Use Object Snaps and Object Snap Tracking
- Modify drawing objects
- Duplicate drawing objects
- Extract information from drawings with measuring tools
- Create and modify hatch patterns
- Create, insert, and modify blocks
- Work with external references
- Import a PDF
- Create and scale paper space layouts and viewports
- Print scale drawings and check plots
- Detail drawings with text, dimensions, and leaders

# Downloading and Installing the Datasets

In order to perform the exercises in this book, you must download a zip file and install the datasets.

Type the address below into your web browser to load the page where you can download the dataset.

**[www.cadapult-software.com/data](http://www.cadapult-software.com/data)**

## Unzip the Files

Unzip the file **APG\_AutoCAD2020.zip** directly to the C drive. The zip file will create the following folder structure:

C:\A Practical Guide\AutoCAD 2020\Files for Exercises

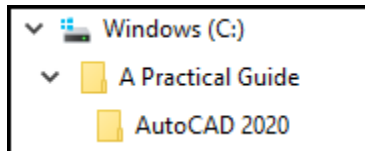

## Exercises

The exercises in this course have been carefully chosen and designed to represent common tasks that are performed by design professionals.

The exercise files are from many different industries, and are meant only to be examples. It's important to focus on the tools being shown and how you could apply them to your project and industry.

Exercises provide higher level process information throughout the exercise tasks. You are given information about not only what to do, but why you are doing it. In most cases, an image is included to help guide you.

# Table of Contents

<b>Chapter 1 Introduction to AutoCAD .....</b>	<b>1</b>
1.1. Lesson: Navigating the AutoCAD User Interface .....	2
1.1.1 Navigating the AutoCAD Interface .....	8
1.2. Lesson: Working with AutoCAD Drawing Files .....	10
1.2.1 Working with AutoCAD Drawings .....	17
1.3. Lesson: Basic AutoCAD Tools .....	20
1.4. Lesson: Selection Techniques.....	26
1.4.1 Selection Techniques.....	29
<b>Chapter 2 Drawing Lines and Working with Layers .....</b>	<b>31</b>
2.1. Lesson: Drawing Lines .....	32
2.1.1 Drawing Lines .....	35
2.2. Lesson: Drawing with Cartesian Coordinates .....	37
2.2.1 Drawing a Rectangle with Absolute Coordinates.....	41
2.2.2 Drawing a More Complex Shape with Absolute Coordinates.....	42
2.2.3 Drawing a Rectangle with Relative Coordinates.....	43
2.2.4 Drawing a More Complex Shape with Relative Coordinates .....	44
2.2.5 Drawing a Rectangle with Polar Coordinates .....	46
2.2.6 Drawing a More Complex Shape with Polar Coordinates.....	47
2.3. Drawing with Polar Tracking.....	49
2.3.1 Drawing a Rectangle with Polar Tracking.....	56
2.3.2 Drawing a More Complex Shape with Polar Tracking .....	58
2.3.3 Drawing with Additional Polar Tracking Angles .....	60
2.3.4 Drawing with Architectural Units .....	62
2.4. Drawing with Layers .....	65
2.4.1 Drawing with Layers.....	72
2.4.2 Changing the Layers of Existing Objects.....	74
2.4.3 Modifying Layer States .....	75
2.4.4 Creating and Modifying Layers .....	77
<b>Chapter 3 Drawing Additional Objects (Part I) .....</b>	<b>81</b>
3.1. Drawing Circles.....	82
3.1.1 Drawing Circles with the Center, Radius and Center, Diameter Methods.....	85
3.1.2 Additional Practice with the Center, Radius and Center, Diameter Methods .....	86
3.1.3 Drawing Circles with the 2-Point and 3-Point Methods.....	87
3.1.4 Drawing Circles with Tangent Methods .....	88

3.2. Drawing Rectangles .....	90
3.2.1 Drawing Rectangles .....	92
3.2.2 Additional Practice Drawing Rectangles .....	94
3.3. Drawing Polygons .....	95
3.3.1 Drawing Polygons.....	98
3.3.2 Additional Practice Drawing Polygons.....	99
<b>Chapter 4 Object Snaps and Object Snap Tracking.....</b>	<b>101</b>
4.1. Drawing with Object Snaps.....	102
4.1.1 Drawing with Endpoint, Midpoint, and Quadrant Object Snaps .....	109
4.1.2 Drawing with Center and Tangent Object Snaps .....	112
4.1.3 Drawing with Node and Perpendicular Object Snaps .....	114
4.1.4 Drawing with Intersection and Geometric Center Object Snaps .....	116
4.1.5 Drawing with Object Snap Overrides .....	118
4.1.6 Additional Practice Drawing with Object Snap Overrides .....	120
4.2. Drawing with Object Snap Tracking.....	122
4.2.1 Tracking Off of a Single Point with Object Snap Tracking .....	127
4.2.2 Object Snap Tracking of Multiple Points .....	129
<b>Chapter 5 Drawing Additional Objects (Part II).....</b>	<b>131</b>
5.1. Drawing Arcs.....	132
5.1.1 Drawing Arcs .....	138
5.1.2 Additional Practice Drawing Arcs .....	140
5.2. Drawing and Editing Polylines .....	143
5.2.1 Drawing Polylines .....	150
5.2.2 Drawing Polylines with Varying Widths .....	152
5.2.3 Editing Polylines .....	155
<b>Chapter 6 Modifying Drawing Objects.....</b>	<b>159</b>
6.1. Moving Drawing Objects .....	160
6.1.1 Moving Drawing Objects.....	162
6.1.2 Additional Practice Moving Objects.....	163
6.2. Scaling Drawing Objects .....	168
6.2.1 Scaling Objects.....	171
6.2.2 Scaling Drawing Objects with the Reference Option .....	174
6.3. Stretching Drawing Objects .....	176
6.3.1 Stretching Drawing Objects .....	178

6.4. Rotating Drawing Objects.....	181
6.4.1 Rotating Drawing Objects .....	185
6.4.2 Rotating Objects with Polar Tracking.....	188
6.4.3 Rotating Objects with the Reference Option.....	190
6.5. Trimming Drawing Objects .....	192
6.5.1 Trimming Drawing Objects.....	196
6.6. Extending Drawing Objects .....	199
6.6.1 Exercise: Extending Drawing Objects.....	203
6.6.2 Exercise: Additional Practice Trimming and Extending Objects.....	204
6.7. Creating Rounded Corners with the Fillet Command.....	209
6.7.1 Filleting Drawing Objects .....	214
6.7.2 Additional Practice Filleting Drawing Objects .....	218
6.8. Creating Angled Corners with the Chamfer Command.....	220
6.8.1 Chamfering Drawing Objects .....	228
<b>Chapter 7 Duplicating Drawing Objects.....</b>	<b>235</b>
7.1. Copying Drawing Objects .....	236
7.1.1 Copying Drawing Objects .....	238
7.1.2 Exercise: Additional Practice Copying Objects.....	240
7.2. Mirroring Drawing Objects .....	242
7.2.1 Mirroring Drawing Objects .....	245
7.2.2 Additional Practice Mirroring Objects.....	247
7.3. Creating Rectangular Arrays of Drawing Objects.....	250
7.3.1 Creating a Rectangular Array .....	254
7.3.2 Additional Practice Creating Rectangular Arrays.....	258
7.4. Creating Polar Arrays of Drawing Objects.....	261
7.4.1 Creating a Polar Array.....	267
7.4.2 Additional Practice Creating Polar Arrays.....	271
7.4.3 Creating Polar Arrays with Multiple Rows.....	273
7.5. Creating Path Arrays of Drawing Objects.....	275
7.5.1 Creating Path Arrays Using the Measure Method .....	280
7.5.2 Creating Path Arrays Using the Divide Method .....	283
7.6. Offsetting Drawing Objects.....	285
7.6.1 Offsetting Drawing Objects .....	289
7.6.2 Additional Practice Offsetting Objects.....	292
7.7. Modifying Drawing Objects with Grips.....	295
7.7.1 Grip Editing Drawing Objects .....	300

<b>Chapter 8 Inquiry Tools</b> .....	<b>305</b>
8.1. Measure commands.....	306
8.1.1 Measuring Distance, Area, and Perimeter .....	322
8.1.2 Measuring Distance, Radius, Area, and Angle .....	325
8.1.3 Measuring Angles.....	329
8.1.4 Measuring with the Quick Measure Tool.....	331
8.2. Object Properties .....	333
8.2.1 Viewing and Modifying Object Properties.....	340
<b>Chapter 9 Adding and Modifying Hatch Patterns</b> .....	<b>345</b>
9.1. Adding and Modifying Hatch Patterns.....	346
9.1.1 Adding Hatch Patterns.....	353
9.1.2 Additional Practice Adding Hatch Patterns.....	357
<b>Chapter 10 Working with Blocks, External References, and PDF Files</b> .....	<b>363</b>
10.1. Inserting Blocks.....	364
10.1.1 Inserting Blocks with the Blocks Palette.....	373
10.1.2 Inserting Dynamic Blocks .....	380
10.1.3 Inserting Blocks with Tool Palettes.....	383
10.1.4 Inserting Blocks with DesignCenter.....	386
10.2. Creating Blocks .....	390
10.2.1 Creating Local Blocks.....	397
10.2.2 Creating Global Blocks.....	403
10.3. Attaching External References.....	408
10.3.1 Working with External References .....	413
10.4. Importing PDF Files .....	418
10.4.1 Importing PDF Files.....	422
<b>Chapter 11 Plotting Drawings</b> .....	<b>427</b>
11.1. Plotting Drawings from Model Space.....	428
11.1.1 Plotting from Model Space .....	431
11.2. Plotting Drawings from Paper Space .....	436
11.2.1 Plotting from Paper Space.....	442
<b>Chapter 12 Annotating Drawings</b> .....	<b>449</b>
12.1. Adding and Modifying Text.....	450
12.1.1 Adding Text Notes to a Drawing.....	455
12.1.2 Additional Practice Adding Text Notes to a Drawing.....	458

12.2. Adding and Modifying Dimensions .....	461
12.2.1 Adding Linear Dimensions .....	471
12.2.2 Adding Aligned and Angular Dimensions .....	473
12.2.3 Adding Radius and Diameter Dimensions .....	475
12.2.4 Adding Continuous and Baseline Dimensions .....	479
12.3. Adding and Modifying Leaders .....	482
12.3.1 Adding Leaders .....	490
12.3.2 Adding Balloons with the Multileader Command .....	493
<b>Index .....</b>	<b>499</b>

## Foreword

Welcome to the wonderful world of AutoCAD. I say that somewhat tongue and cheek as learning AutoCAD can be somewhat daunting – and no doubt why you’ve chosen to pick up this book. I commend you for not trying to learn AutoCAD completely on your own (a dreadful route to take) but for relying on the skillful guidance of Tracy Chadwick and Rick Ellis. These two award winning authors have been teaching AutoCAD for many years and know exactly what it takes to lead the beginning user through the oft overwhelming tools inside of AutoCAD. This ***A Practical Guide of AutoCAD 2020*** will focus on the all-important basics of the product and steer you clear of the nonessential tools (you can tackle those later when you are more seasoned!) There is a right and a wrong way to use AutoCAD...this book will ensure that you learn how to use it the “right” way!

I taught AutoCAD at the collegiate and professional level for 11 years before joining Autodesk in their training department. I know the importance of good training materials and I know a great AutoCAD book when I see it. You are looking at one right now. Tracy and Rick have mastered the art of writing in terms that we can all understand without a need to impress or complicate the task at hand. Their goal is simple: to help you successfully use AutoCAD for your design work. They have taken their many years of training expertise and rolled it all into this well massaged book. How I wish I’d had this book when I was training people how to use AutoCAD!

In my 20+ year role as Autodesk Evangelist, I had the distinct privilege of working with Tracy and Rick at Autodesk University and other conferences. Their presentations are always highly rated and very popular with attendees. They have that special knack of connecting with an audience and making the difficult sound easy – which is exactly what you need when you are learning to use AutoCAD. You will experience this as you make your way through the chapters of this book.

***A Practical Guide of AutoCAD 2020*** also includes real-world examples from many different industries. You won’t be drawing any Mickey Mouses or smiley faces, but actual drafting examples. Let’s face it – you wouldn’t get a job with that limited skillset (well...unless you go work for Disney). The variety of practical examples used with practical commands is the perfect combination to get you prepared for drafting and designing in the real world.

Use this book to build a firm foundation for designing with AutoCAD. Those users with a firm foundation of the product do best overall in successfully mastering the product (another reason to read this book). Physically do as many exercises in the book as possible and you’ll be on the road to becoming a great AutoCAD user!

I’m pretty sure that your first thought when you’re finished with this book is going to be...“When are Tracy and Rick going to come out with an ***Advanced Practical Guide of AutoCAD?***” I know that’s my question!

*Lynn Allen*

Global Technology Evangelist

In her 20+ year career as Autodesk Technology Evangelist, Lynn Allen has spoken to more than a half million design professionals in over 50 countries throughout the world. Her online reach over the years easily reaches into the millions. An early CAD entrepreneur, Lynn taught AutoCAD at the corporate and collegiate level for 11 years before joining Autodesk. A popular columnist for Cadalyst magazine for over two decades, she is the face behind hundreds of software videos including the series “AutoCAD Tips and Tricks with Lynn Allen”. A sought-after public speaker with a unique comedic style, Lynn was the host of Autodesk University for over a decade and is always one of the highest rated presenters at the many worldwide Autodesk Universities. She is also the author of three technical books focused on AutoCAD software.

# Sample Lesson

## 6.4. Rotating Drawing Objects

### Introduction

In this lesson, you learn how to rotate drawing objects.

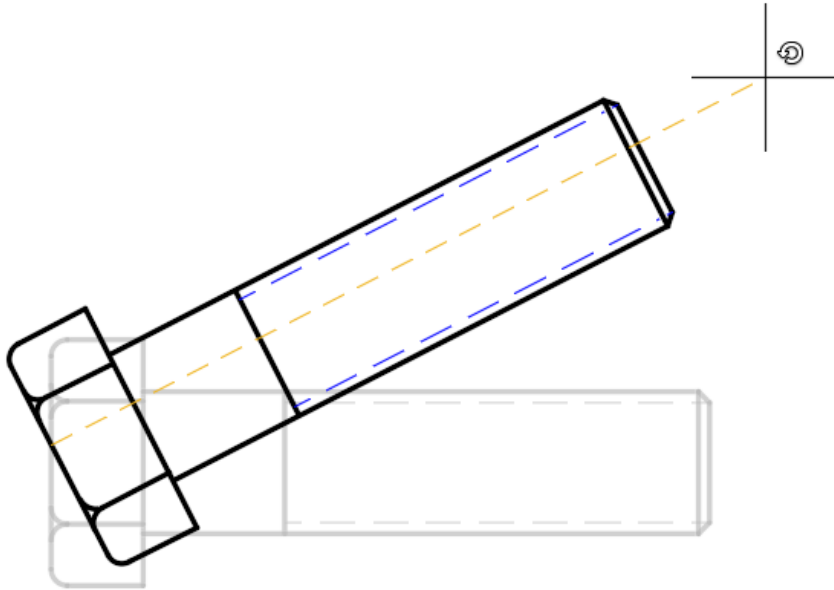

### Key Concepts

Concepts and key terms covered in this lesson are:

- Rotating Objects
- Base Point
- Rotation Angle
- Reference Angle

### Objectives

After completing this lesson, you will be able to:

- Rotate drawing objects.

## About the Rotate Command

Many times while drawing you will have the need to adjust the orientation of drawing objects by rotating them. The Rotate command can achieve this in a few simple steps.

## Starting the Rotate Command

The **Rotate** command is located at **Ribbon: Home** ⇒ **Modify** ⇒ **Rotate**.

Alternatively, you can type **RO** then press **[Enter]** at the keyboard.

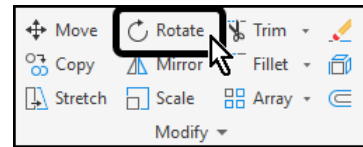

After starting the Rotate command, you are prompted to select the objects to be rotated.

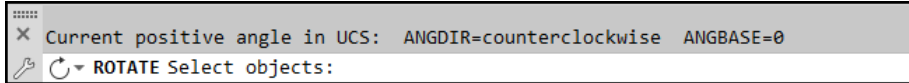

The Rotate command will allow you to select as many objects as you want. When you are finished selecting objects you must press **[Enter]** at the keyboard to move on to the next step.



Next you will specify the base point. This point will remain in the same location while the rest of the selected objects rotate around it.



Finally, the Command line asks for the rotation angle. The angle can be specified by typing a value or by selecting a point on-screen.

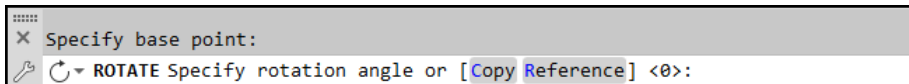

When entering a rotation angle value, it is important to remember that by default in AutoCAD, angles are positive when rotating in the counterclockwise direction; angles are negative when rotating in the clockwise direction.

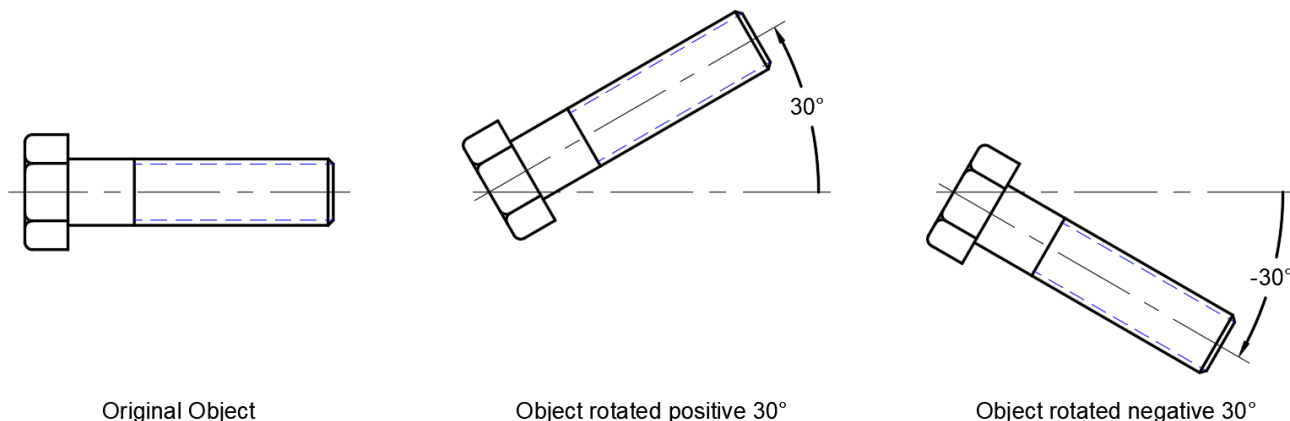

Instead of typing the rotation angle value, you can also pick a point on-screen. Turn on *Polar Tracking* to ensure that the rotation angle is precise. In the example below the Incremental Angle value of *Polar Tracking* has been set to 30 degrees. This could be a more efficient workflow because you do not need to be concerned with whether or not an angle is positive or negative. Instead, you simply click when the object is located on the appropriate tracking angle.

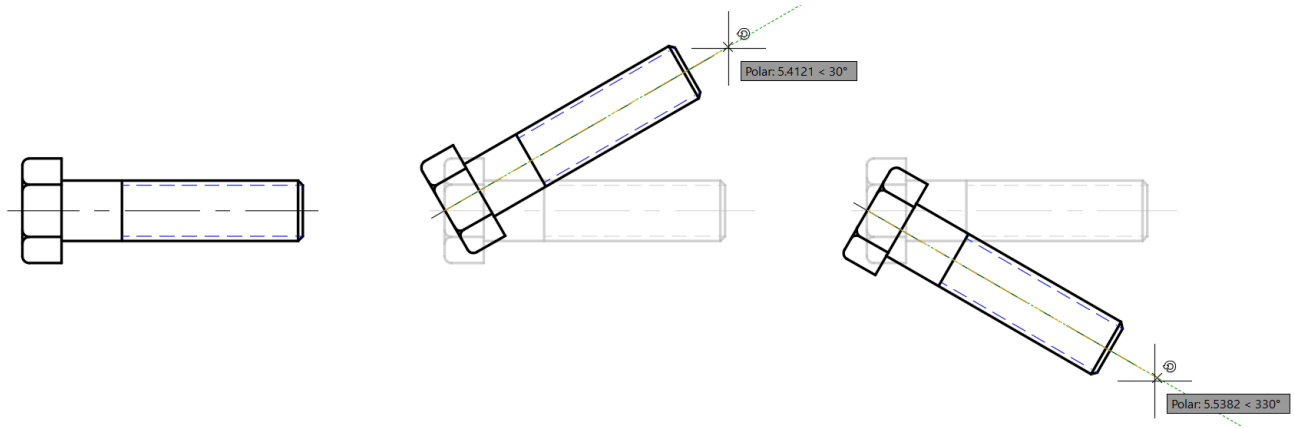

### Specifying the Reference Angle

Occasionally when working in a drawing, you may find the need to rotate an object to return it to a standard orientation. For example, the bolt in the image to the right is currently at an angle, and it needs to be rotated until it is back to horizontal.

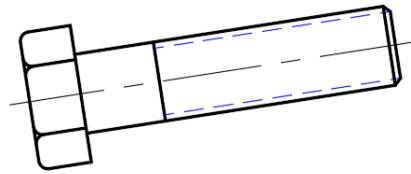

This is a fairly simple process if the object was rotated at a known angle, such as 30 degrees; you could simply rotate the object negative 30 degrees to return it to horizontal. However, if the object has been rotated at an unknown angle, the process could be more difficult. One possibility is to measure the angle from horizontal, then rotate using a negative value.

In the image to the right, the angle of the bolt has been measured and found to be nine degrees.

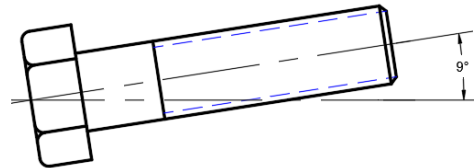

The first instinct might be to rotate the object negative nine degrees to return it to horizontal. This might not work precisely, because the nine degree dimension could be rounded off. A closer look reveals that the angle is slightly less.

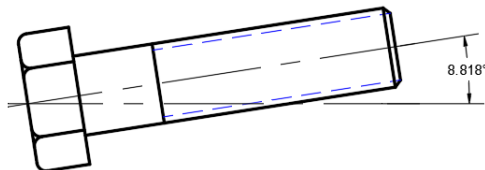

Using this new, more precise value could still lead to an incorrect drawing because this value is most likely rounded off as well.

The much more precise and quicker solution is to use the Reference option of the Rotate command.

In this example the centerline of the bolt will serve as the reference angle. Therefore, the left endpoint of the centerline will serve as the basepoint.

1. Begin the Rotate command and select the objects to be rotated.
2. Specify the basepoint.
3. Choose the **[Reference]** option in the Command line.

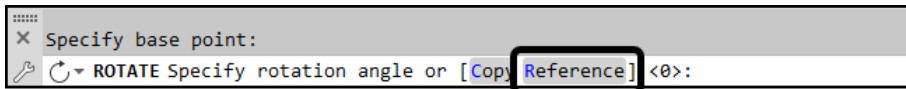
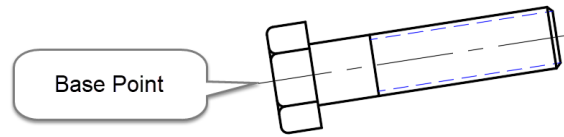

4. Select the two endpoints of the centerline to represent the new reference angle.

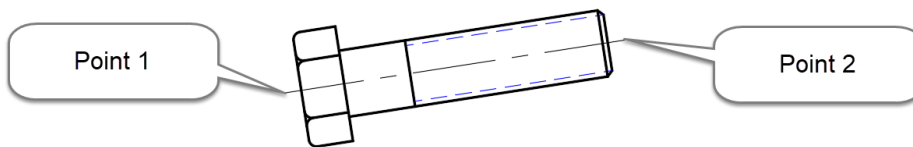

5. Move the crosshairs horizontally to the right of the basepoint along the **0** degree *Polar Tracking* angle.
6. Select a point to rotate the bolt into place.

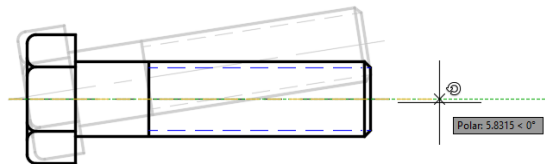

### Exercises: Rotating Drawing Objects

In these exercises, you will rotate several drawing objects.

You do the following:

- Start the Rotate command.
- Select objects.
- Specify base points.
- Specify a rotation angle by typing a value.
- Specify a rotation angle with *Polar Tracking*.
- Use the reference option to orient drawing objects.

### 6.4.1 Rotating Drawing Objects

In this exercise you will use the Rotate command to adjust the orientation of several doors.

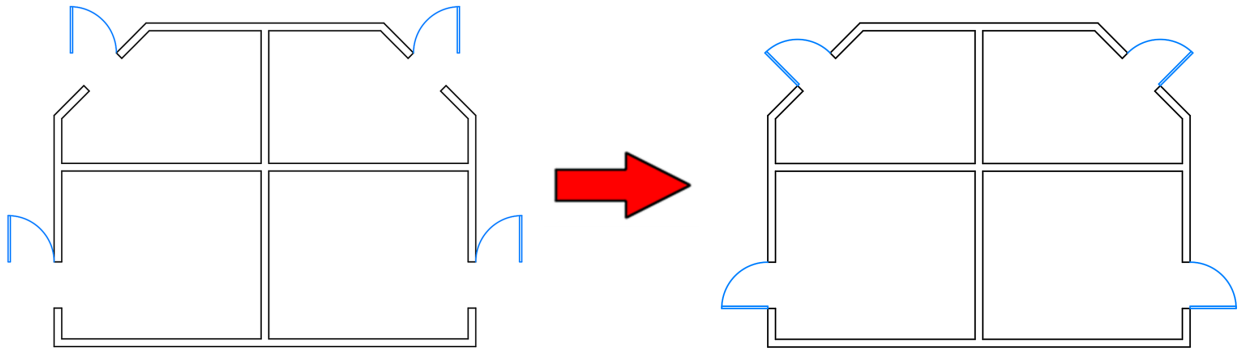

1. **Open drawing 6.4.1 Rotating Objects 1.dwg.**
2. Set **Endpoint** as a *Running Object Snap*.

Four doors have been placed, but they need to be rotated into place. Start with the door in the lower left, then work clockwise around the building.

3. Zoom to the lower-left quadrant of the building.
4. Select **Ribbon: Home** ⇒ **Modify** ⇒ **Rotate**.

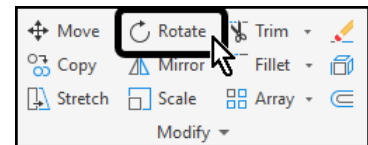

5. Select the door.
6. Press **[Enter]** at the keyboard to finish selecting objects.

You are now prompted to select the base point.

7. Select the point where the arc touches the wall to specify it as the base point.

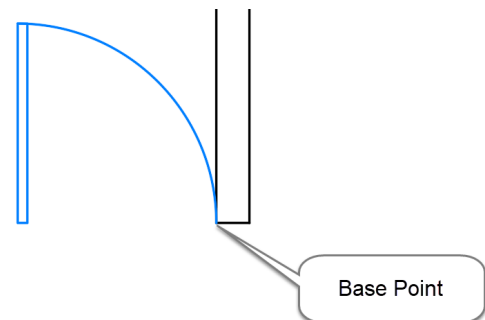

You are now prompted to specify the rotation angle.

8. At the Command line type **90** then press **[Enter]** at the keyboard.

The door is rotated into place.

9. Zoom to the upper-left quadrant of the building.

10. Select **Ribbon: Home** ⇒ **Modify** ⇒ **Rotate**.

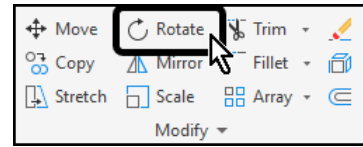

11. Select the door.

12. Press **[Enter]** at the keyboard to finish selecting objects.

You are now prompted to select the base point.

13. Select the point where the arc touches the wall to specify it as the base point.

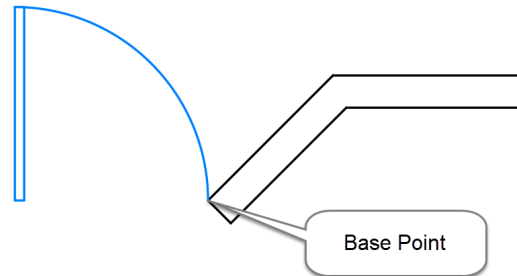

You are now prompted to specify the rotation angle.

14. At the Command line type **45** then press **[Enter]** at the keyboard.

The last two doors will be rotated in the clockwise direction, which will require negative rotation angles.

15. Zoom to the upper-right quadrant of the building.

16. Select **Ribbon: Home** ⇒ **Modify** ⇒ **Rotate**.

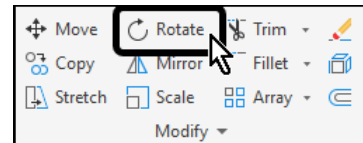

17. Select the door.

18. Press **[Enter]** at the keyboard to finish selecting objects.

You are now prompted to select the base point.

19. Select the point where the arc touches the wall to specify it as the base point.

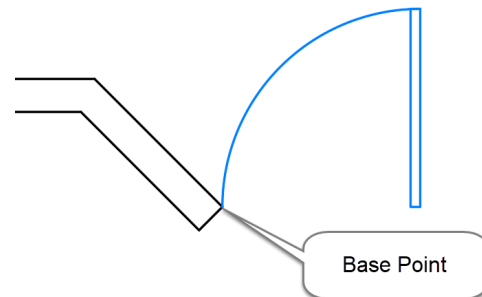

You are now prompted to specify the rotation angle.

20. At the Command line type **-45** then press **[Enter]** at the keyboard.

Next you will rotate the final door.

21. Zoom to the lower-right quadrant of the building.

22. Select **Ribbon: Home** ⇒ **Modify** ⇒ **Rotate**.

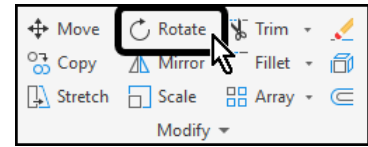

23. Select the door.

24. Press **[Enter]** at the keyboard to finish selecting objects.

You are now prompted to select the base point.

25. Select the point where the arc touches the wall to specify it as the base point.

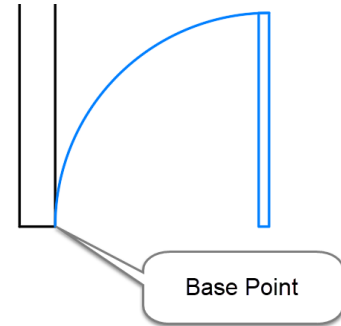

You are now prompted to specify the rotation angle.

At the Command line type **-90** then press **[Enter]** at the keyboard.

The completed drawing appears as shown.

26. **Save** the drawing.

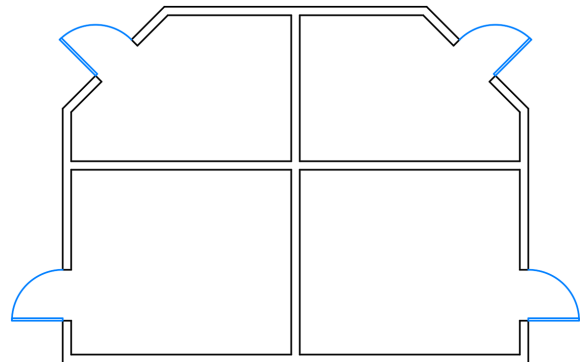

## 6.4.2 Rotating Objects with Polar Tracking

In this exercise you will use the Rotate command and *Polar Tracking* to speed up the rotate process.

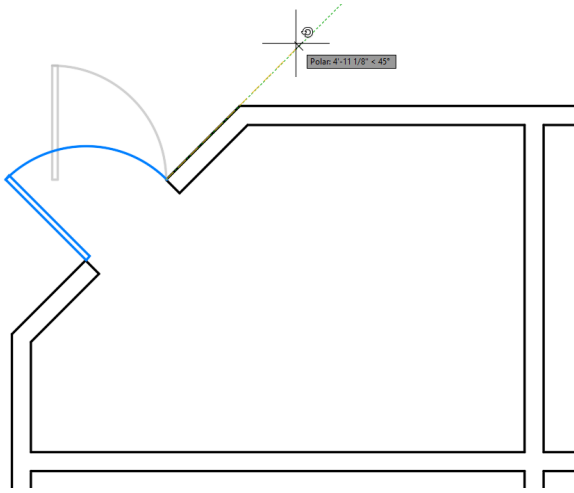

1. **Open** drawing **6.4.2 Rotating Objects 2.dwg**.
2. Set **Endpoint** as a *Running Object Snap*.
3. Select the fly-out arrow next to the *Polar Tracking* button and select **45** degree increment angles.
4. If necessary, select the *Polar Tracking* button to turn it on.

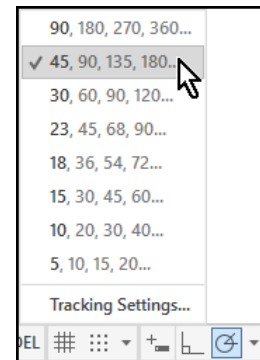

5. Zoom to the lower-left quadrant of the building.
6. Select **Ribbon: Home** ⇒ **Modify** ⇒ **Rotate**.

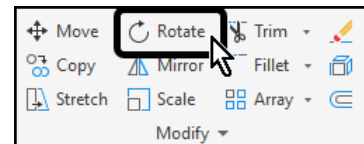

7. Select the door.
8. Press **[Enter]** at the keyboard to finish selecting objects.

You are now prompted to select the base point.

9. Select the point where the arc touches the wall to specify it as the base point.

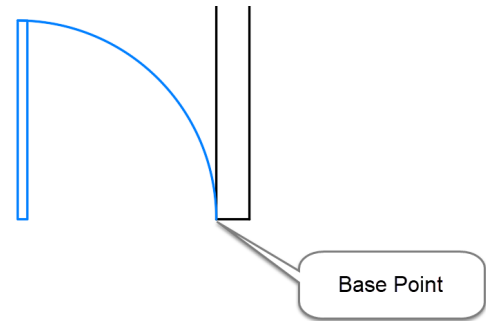

You are now prompted to specify the rotation angle.

10. Move the crosshairs above the previous point, until it snaps on to the **90** degree *Polar Tracking* angle, then select a point.

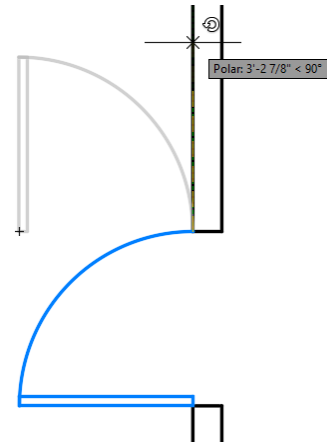

The door is rotated into place.

11. Zoom to the upper-left quadrant of the building.
12. Select **Ribbon: Home** ⇒ **Modify** ⇒ **Rotate**.

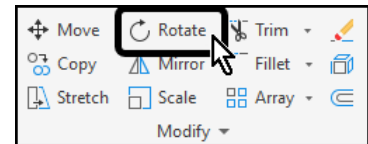

13. Select the door.
14. Press **[Enter]** at the keyboard to finish selecting objects.

You are now prompted to select the base point.

15. Select the point where the arc touches the wall to specify it as the base point.

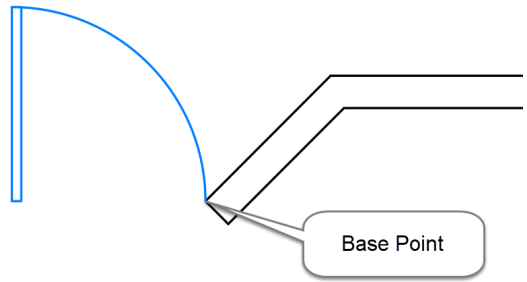

You are now prompted to specify the rotation angle.

16. Move the crosshairs above and to the right of the previous point, until it snaps on to the **45 degree Polar Tracking** angle, then select a point.

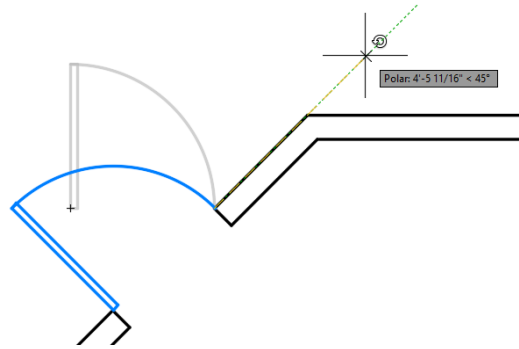

17. Repeat the process to complete the right side of the drawing.
18. **Save** the drawing.

### 6.4.3 Rotating Objects with the Reference Option

In this exercise you will use the Reference option of the Rotate command to adjust the orientation of an object.

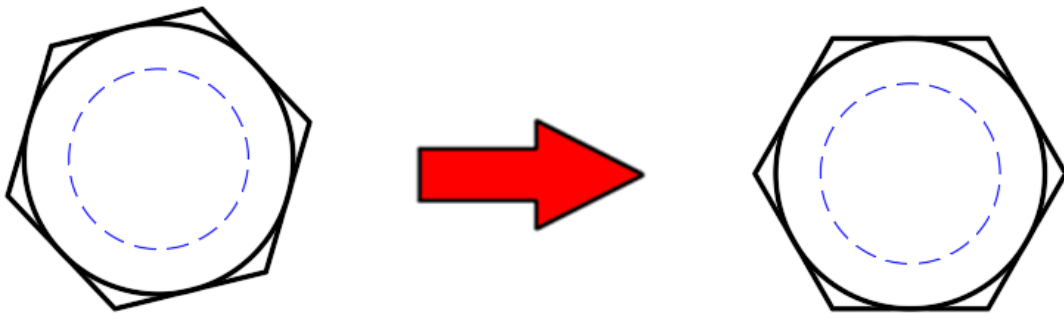

1. **Open** drawing **6.4.3 Rotating Objects 3.dwg**.
2. Set **Endpoint** as a Running Object Snap.

A bolt head has been rotated at an unknown angle. You will rotate it until the top and bottom edges are horizontal.

3. Select **Ribbon: Home** ⇒ **Modify** ⇒ **Rotate**.

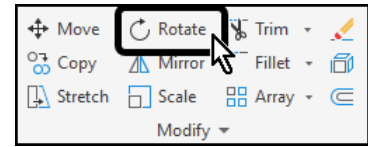

4. Select the objects that make up the bolt head.
5. Press **[Enter]** at the keyboard to finish selecting objects.

You are now prompted to select the base point.

6. Select the lower-left corner to specify it as the base point.

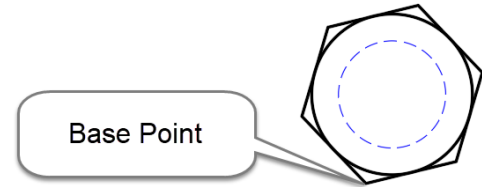

You are prompted for a rotation angle. By default, AutoCAD uses 0 as the reference angle, meaning that you are rotating from horizontal. In this case the reference angle should match the bottom edge of the bolt head. Since that value is unknown, you will select the two endpoints of that line to specify it as the new reference angle.

7. At the Command line select the **[Reference]** option.

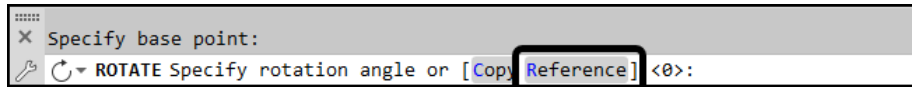

You are prompted to specify the reference angle.

8. Click the lower-left point.
9. Click the lower-right point.

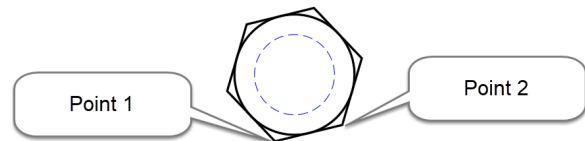

The reference angle now matches the bottom edge of the bolt head.

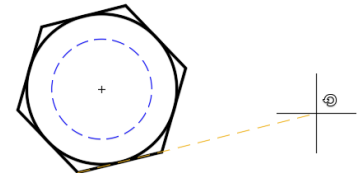

10. Move the crosshairs horizontally to the right along the **0** degree *Polar Tracking* angle.
11. Select a point to rotate the bolt head into place.

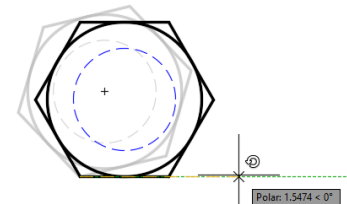

The top and bottom edges of the bolt head are now horizontal.

12. **Save** the drawing.

### Lesson Review

In this lesson, you learned how to rotate drawing objects both by typing angle values at the Command line and with the aid of *Polar Tracking*.

## Index

[F2]	22	External References	408
Absolute Coordinates	38	External References Palette	409
Additional Tracking Angles	52	File Tabs	6
Aligned Dimension	464	File Types	11
Angles	40	Fillet command	210
Angular Dimension	465	Freezing and Thawing Layers	67
Application Menu	5	Geometric Center Snap	106
Arc	133	Grip Editing	296
Area	316	Hatch patterns	347
Associative Dimensions	468	Help	6
automatic save	15	Increment Tracking Angles	50
automatic save files	15	Inscribed	96
<b>backup copy</b>	15	Insert command	409, 419
Baseline Dimension	467	Insert Snap	108
Block Editor	394	Inserting Blocks	365
Blocks	365, 409	Intersection Snap	106
Boundary edges	200	Joining Lines and Arcs	148
Cartesian Coordinates	38	Keyboard Options	21
Center Snap	106	Lasso	28
Chamfer command	221	Layer Properties Manager	69
Changing the Layer of Existing Objects	66	Layer States	67
Circle	83	Layers	66
Circumscribed	97	Layout Tabs	7
Closing a File	16	Layouts	439
Closing a Polyline	147	Leaders	483
Command Line	7	Line	33
Command Line Options	22	Linear Dimension	464
Continue Dimension	466	Linetype	70
Copy command	237	Lineweight	71
Create Block command	391	List command	335
Crosshairs	6	Locking Layers	68
Crossing selection method	27	Match Properties	334, 350
Current Layer	66	Measure Angle	313, 314
Cutting edges	193	Measure Area	316
DesignCenter	372	Measure Commands	307
Diameter Dimension	466	Measure Distance	309
Dimensioning	462	Measure Radius	311
Direct Distance Entry	50	Midpoint Snap	105
Drafting Settings Dialog Box	104	Mirror command	243
Drawing Units	308	Model Space	429, 440
Drawing Window	6	Move command	161
Dynamic Blocks	370	Multileader	483
Edit Polyline	146	Multiline Text	451
Endpoint Snap	105	Multiple Drawings	16
Erasing Objects	25	Navigation Bar	24
Explode	149, 264, 368	Nearest Snap	108
Extend command	200	New	11
Extension Snap	125	Node Snap	108
External Reference Fading	411	Object Snap Tracking	123
External Reference Path Type	411	Object Snaps	103, 125
External Reference Type	410	Offset command	286
External Reference Updating	411	Open	13

ORTHO	50	Reference Angle	183
OSNAP	103	Reference Option	169
OTRACK	123	Relative Coordinates	39
Page Setup Manager	437	Removing objects from a selection set	28
Pan	24	Ribbons	5
Paper Space	437	Right-Click Context Menus	23
Parallel Snap	126	Rotate command	182
Path Array	276	Running Object Snaps	103
PDF data to import	420	Save	14
PDF Import	419	Save As	14
Perpendicular Snap	107	Scale command	169
Plot style table	430	Selection Techniques	26
Plotting	429, 437	Status Bar	7
Polar Array	262	Stretch command	177
Polar Coordinates	40	Tangent Snap	107
Polar Tracking	50	Text	451
Polygon	96	Text Window	22
polyline	91	Tool Palettes	371
Polyline Width	145, 147	Tracking Angles	125
Polylines	144	Trim command	193
Properties palette	337	Turning Layers On and Off	67
Properties Panel	334	UCS Icon	7
QNew	11	Undo	25, 34
Quadrant Snap	107	Units	53, 308
Quick Access Toolbar	6	View Cube	6, 24
Quick Measure	320	Viewport Scale	441
Quick Select	339	Viewports	439
Radius Dimension	465	Window selection method	27
Rectangle	91	Write Block command	393
Rectangular Array	251	Zoom	24
Redo	25		